

LANE MASTER XTREME



IMPORTANT



Be Sure
to Read this
Manual
Before Use

UNIS[®]

UNIS TECHNOLOGY

NOTE: Some portions of assembly may require additional assistance.

Operation Manual

WE ARE HERE TO ASSIST For parts and service



Have Questions? Contact us!

UNIS SERVICE CENTER
Tel: 972-241-4263
Email: service@unispartsandservice.com
www.unispartsandservice.com

When contacting Service, you will need the following information and the name of your authorized distributor.

INDOOR MACHINE	
NAME: Lane Master Xtreme GMP	MAX POWER: 700W
MODEL: C-765	MIN POWER: 550W
S/N:	FREQUENCY: 50/60Hz
VOLTAGE: AC110V~	DATE:
Guangdong UNIS Technology Co.,Ltd.	

CONTENT

IMPORTANT SAFETY INSTRUCTIONS..... 3

1. SPECIFICATIONS 5

2. CONTENTS OF THE ACCESSORY KIT 7

3. PART NAME 8

4. SET UP & INSTALLATION 9

5. HOW TO PLAY 18

6. GAME OPTION21

7. TROUBLESHOOTINGS26

8. MAINTENANCE & INSPECTION30

9. OVERALL CONSTRUCTION 33

10. WIRING DIAGRAM 71

Thank you for purchasing **Lane Master Xtreme GMP**. We hope you enjoy the product.

This manual contains valuable information about how to operate and maintain your game machine properly and safely. It is intended for the owner and/or personnel in charge of product operation. Carefully read and understand the instructions.

If you need any help during installation and setup please utilize this manual and troubleshooting guide. If the product fails to function properly, *non-technical personnel should under no circumstance attempt to service the machine*. Contact your distributor or manufacturer for help.

Before use, please read **IMPORTANT SAFETY INSTRUCTIONS**.

IMPORTANT SAFETY INSTRUCTIONS

To ensure the safe usage of this product, carefully read and understand these instructions before operating your game.

Save these instructions for future reference.

Use this product only as described in this manual. Other uses not recommended may cause fire, electric shock or personal injury. Unplug the game from the outlet when not in use, when moving from one location to another, and before cleaning/servicing.

Explanations which require special attention are indicated by signs of warning. Depending on the potential hazardous degree, the terms: **NOTE**, **NOTICE**, and **WARNING** are used.

NOTE: A NOTE indicates useful hints or information about product usage.

NOTICE: A NOTICE indicates potential damage to product and how to avoid the problem.

WARNING: A WARNING indicates a potential for product damage or serious personal injury.

It is important to understand the meaning of the following HAZARD SIGNS before continuing:

High Voltage and Shock Hazard:

High voltage can cause electric shock.
Turn off/unplug power before servicing.



High Temperature Hazard:

This part may cause scalding.
Do not touch. Surface may be hot.



No Touching Hazard:

This part may be hot or can cause electric shock.
Do not touch.



Use the following safety guidelines to help ensure your own personal safety and to help protect your equipment and surrounding environment from potential damage.

⚠ This product is an indoor game machine. Do not install outdoors.

Avoid installing in the following places to prevent fire, electric shock, injury and/or machine malfunctioning:

- Places subject to rain/moisture, or places subject to high humidity.
- Places subject to direct sunlight, or places subject to extremely hot or cold temperatures to ensure that it is used within the specified operating range.
- Places where inflammable gas may be present or in the vicinity of highly inflammable/volatile chemicals or items that can easily catch fire.
- On unstable or sloped surfaces. The machine may topple or cause unforeseen accidents.
- Vicinity of fire exits, fire extinguishers etc that may block/prevent safety measures.

IMPORTANT NOTE:

ALL REPAIRS MUST BE DONE TO ORIGINAL MANUFACTURER SPECIFICATIONS. FAILURE TO DO SO VOID ALL WARRANTIES AND OPERATOR ASSUMES ALL RISKS.

Note: The contents of this manual may be updated without notice.

1. SPECIFICATIONS

Rated power supply: AC110V 50/60Hz;

Min. Power consumption: 550W

Max. Power consumption: 700W

Dimension: H105.41×W65.19×D112.96 in

H2677.6×W1656 ×D2869.4 mm

Weight: Approximately 1212.54 lb/550 KG

Model No: C-765

Part No.: L129

! **NOTICE** : After turning off the game, please wait at least 1 minute before restarting again.

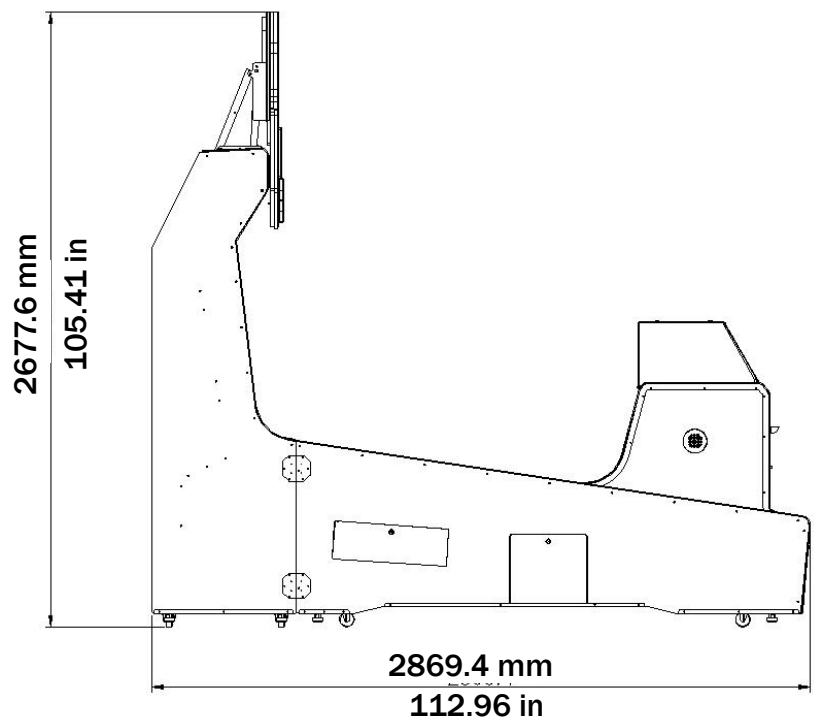
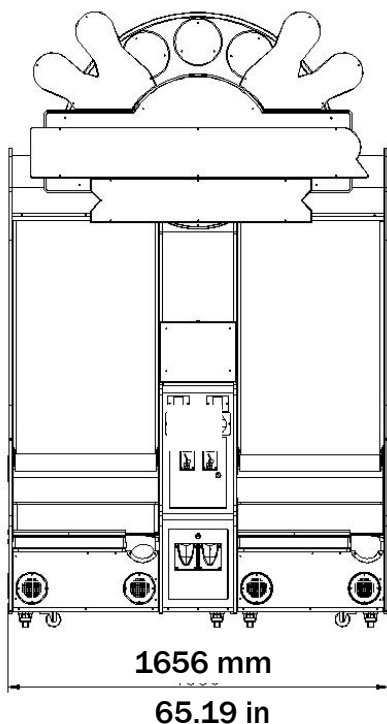

Note: Game specifications are subject to change without notice.

This machine will be divided into two parts during transportation.

Back Cabinet: H82.27×W65.19×D26.39 in

H2089.8×W1656×D669.3 mm

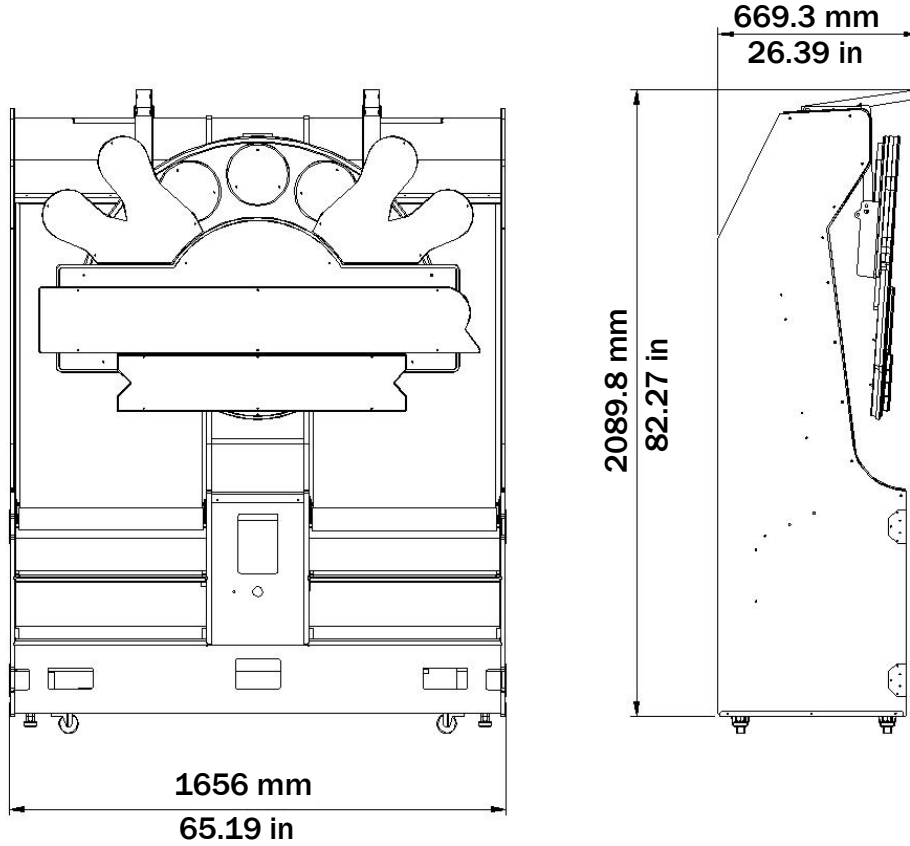

Ally part: H52.32×W65.19×D88.14 in

H1329×W1656×D2239 mm

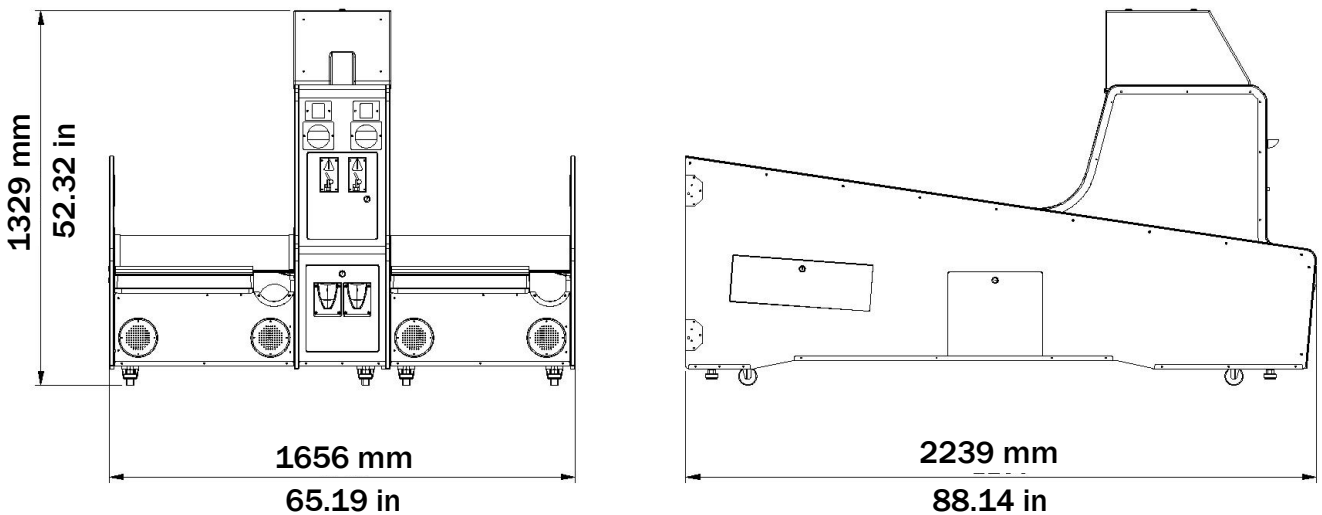











Note: Game specifications are subject to change without notice.

2. CONTENTS OF THE ACCESSORY KIT

Open the package and make sure all the items are included:

1. Following accessories

No.	Part No.	Code No.	Name	Qty	Picture
1	L129-0801-00	2.53.00171002	171A key	2	
2	L129-0802-00	2.53.00172002	171B key	1	
3	L129-0803-00	2.33.01.010020	Power cord 3×16AWG 1.8M	1	
4	L129-0804-00	4.14.40000685	Manual	1	
5	L129-0806-00	4.06.07.000012	Wrench	2	
6	L129-0805-00	206.1.1605.027C	Bowling ball	4	
7	L129-0809-00	23302000012	Network cable T568A-T568A 5M	1	
8	L129-0619-00	2.19.01.000030	Fuse Φ5×20mm T10A 125VAC	2	
9	L129-0808-00	4.10.04000135	Power ball(Transparent)	16	
10	L129-0807-00	4.10.04000136	Power ball	64	

Note: Game specifications are subject to change without notice.

3. PART NAME

Key Components



4. SET UP & INSTALLATION

⚠ NOTICE

We do not recommend using power tools as they may cause damage.

⚠ **This product is an indoor game machine. Do not install outdoors.**

- Refer to IMPORTANT SAFETY INSTRUCTIONS (Pg. 3) for places to avoid.
- Place the unit on a dry level surface.
- Ventilation openings in the back of the unit must not be obstructed by objects or by wall.

4.1 Transporting the Game

If you need to move the game, adjust the levelers back to an “up” position.

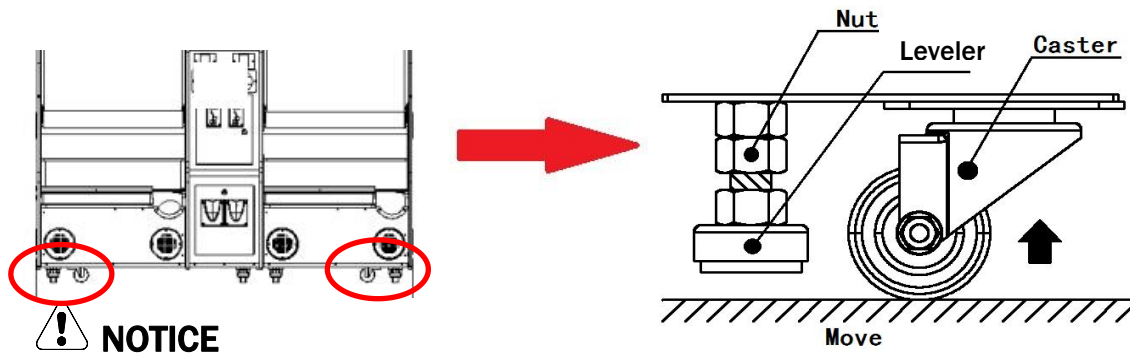

⚠ NOTICE

- Be careful not to damage the machine during transport.
- Always unplug the game before moving.
- Keep the machine in upright position during transport.
- For longer distance transport, package the game properly to prevent damages.

4.2 Level Adjustment

Install this game on a flat surface. If the game is installed on an unsuitable floor, it could cause game malfunction.

To secure the game, loosen the nut, utilize wrench to adjust the leveler down until it touches the floor, lifting the casters off the ground by 0.2 in/5mm. Repeat the same for all levelers.

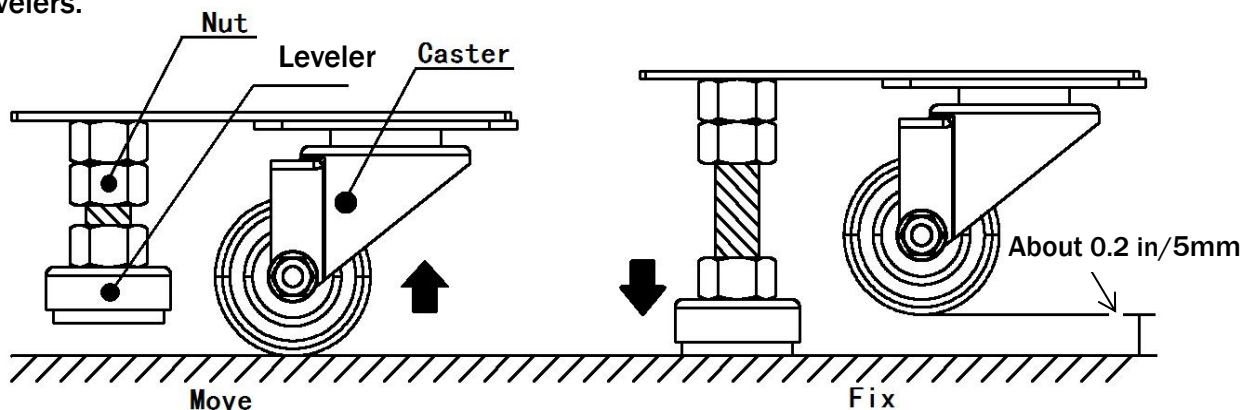

⚠ NOTICE

Make sure the machine is level.

4.3 Play Zone

This machine requires space for playing and for maintenance as shown below.
Leave space around the game upon installation:

Service area: 20 in

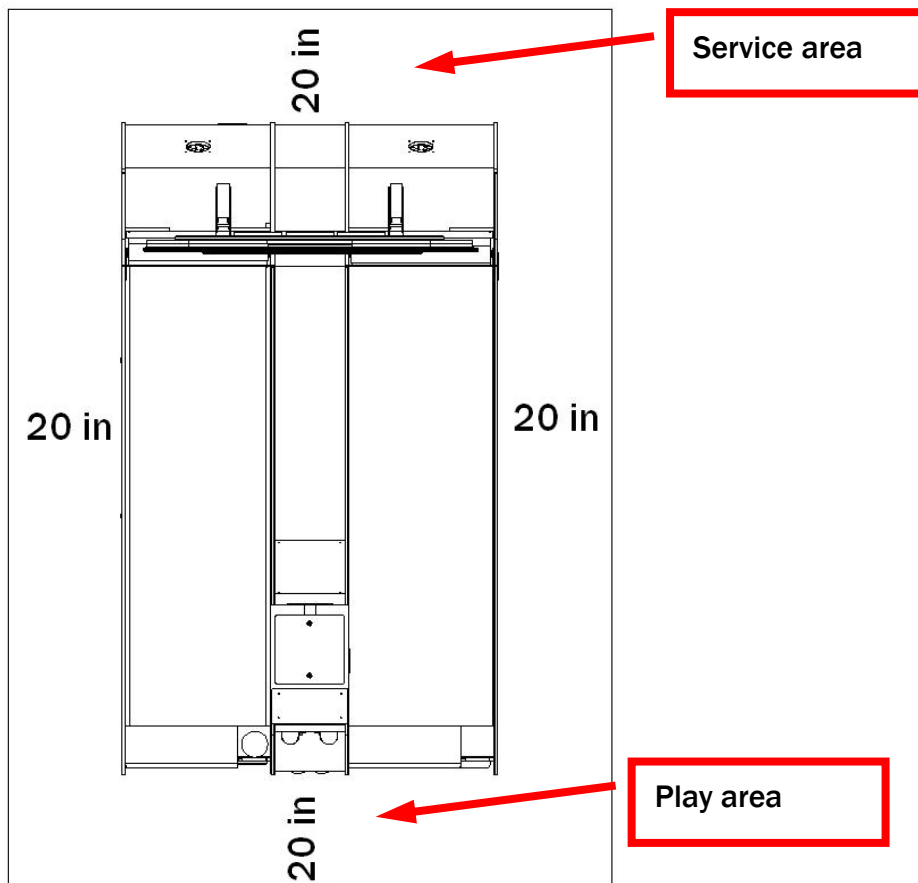



NOTICE

Your unit must be leveled to operate properly.

4.4 Machine Installation

Before processing with assembly assure you have the following tools.

No.	Name	Picture	Use for
1	Phillips screwdriver		For Marquee Installation & Connect Lane Assembly
2	Wrench		
3	Allen hexagon wrenches		Connect Lane Assembly & Display Assembly

Installation Instructions

Step 1 Place the 2 Lane Assemblies together.

Step 2 Open the coin door and the ticket door to bolt the lanes together utilizing the hardware indicated by the red arrows.

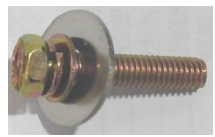
No.	Name	Picture	Qty
1	Cross recessed hexagon screw		8
	C flat washer		8

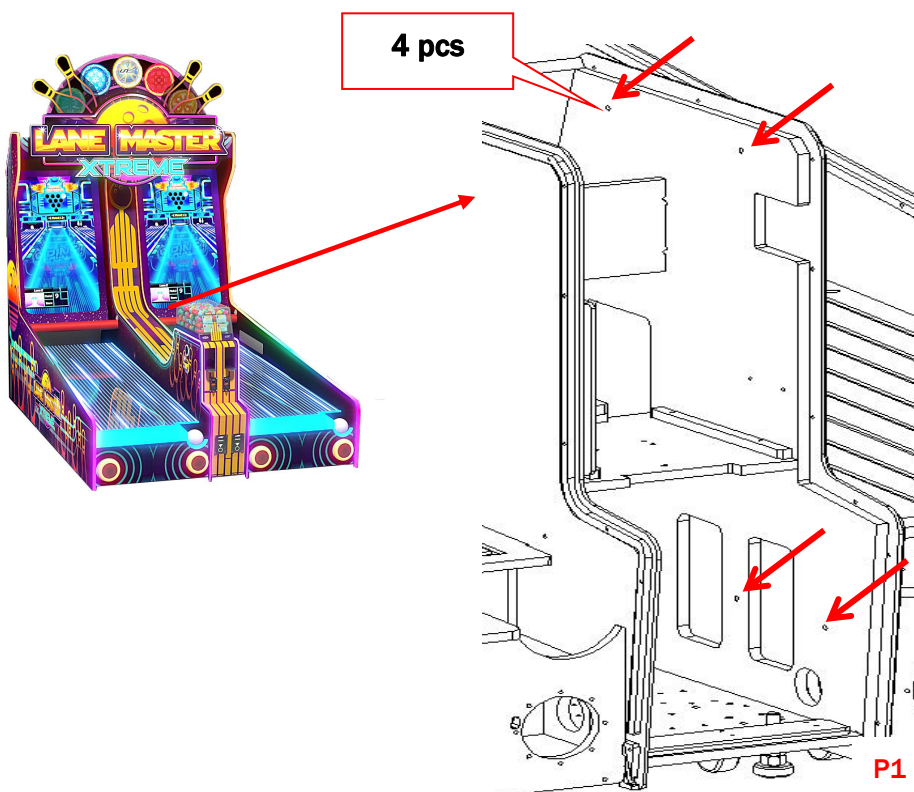

Step 3 Open the back plate and attach the screws in the red arrow area.

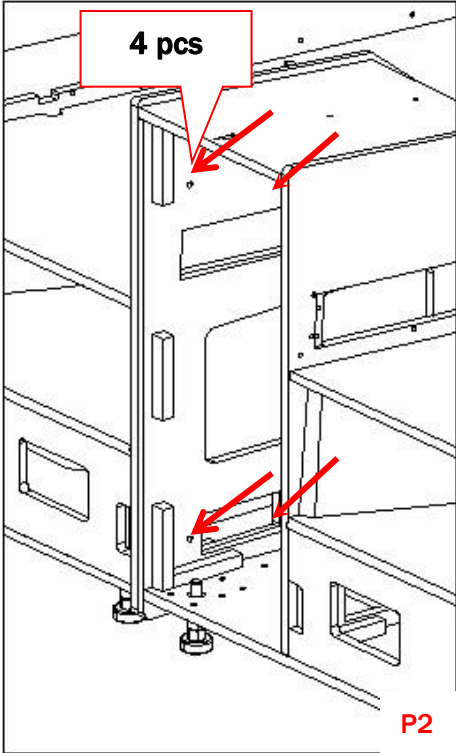

Step 4 Install Hopper assy. to the middle top of the lane.

No.	Name	Picture	Qty
1	Hexagon screws		2

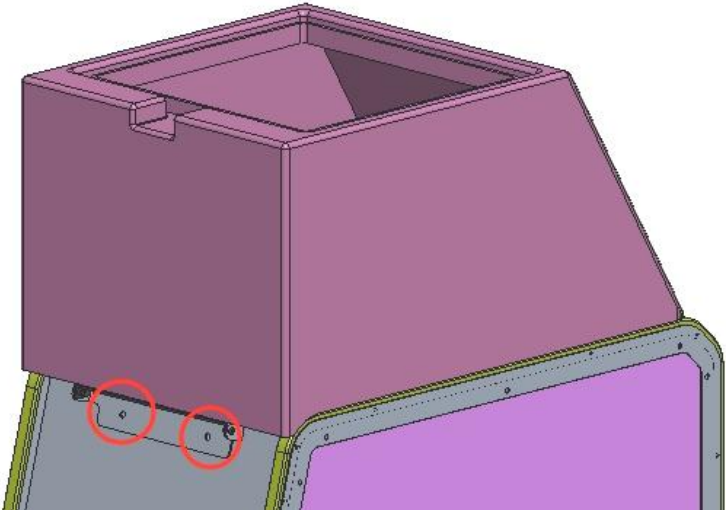

Step 5 Open Coin door, Secure buckle. Connect all the connectors

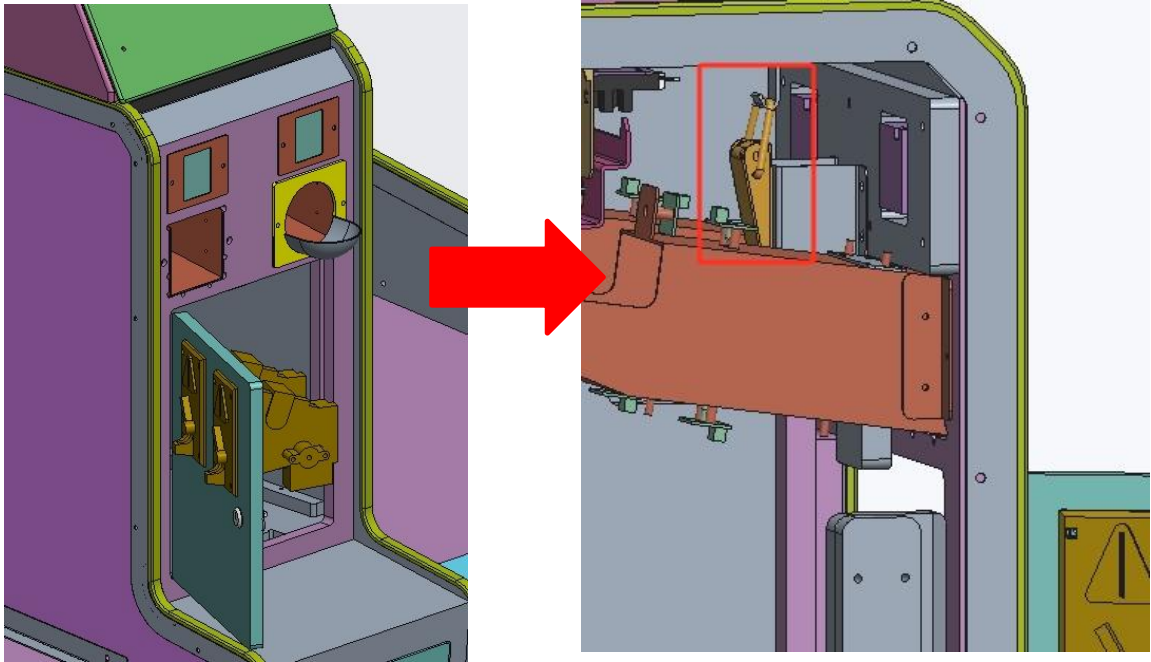

Step 6 Align Monitor cabinet with the Lane assy.

Use the Allen hexagon wrench (Provided) to lock the back box with the lanes as indicated.



Step 7 Lower leg levelers into place for initial leveling of the back box and the lanes if the floor is uneven.

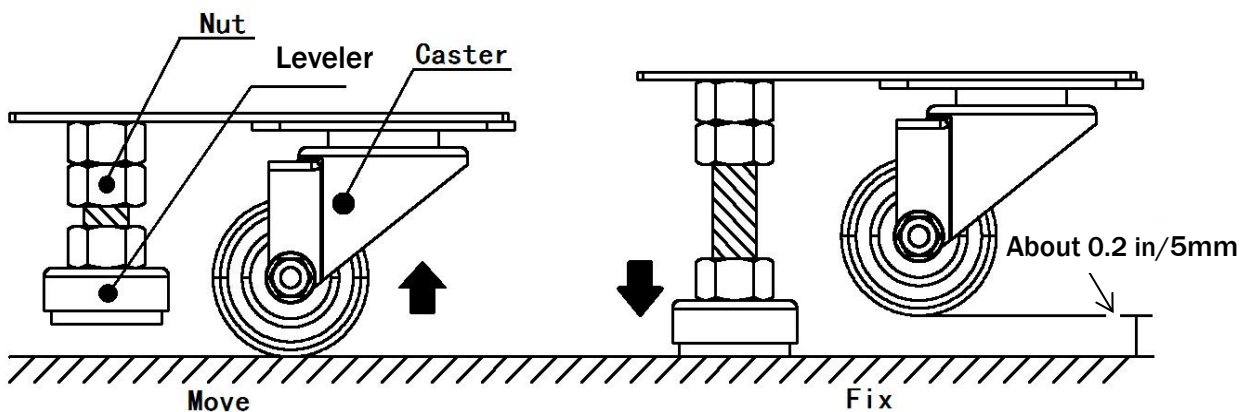

Step 8 Lift the marquee into place and attach to the bracket. Install hardware where indicated by the red arrows.

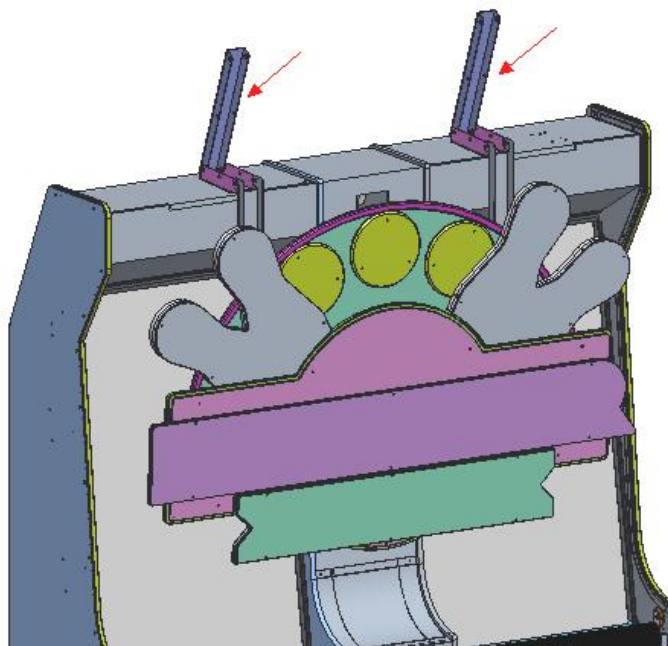

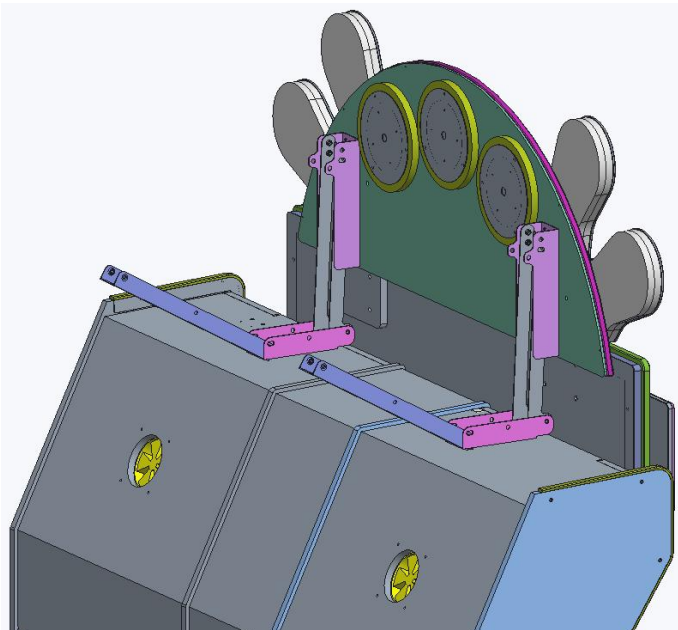

Step 9 Attach support bracket.

Note: It is recommended to have the minimum of two staff members available for this installation.



Step 10 Install the bolts as indicated in the green area.

Kit list:

No.	Name	Picture	Qty
1	Cross recessed hexagon bolt set		8
2	Fixed connected rod		2

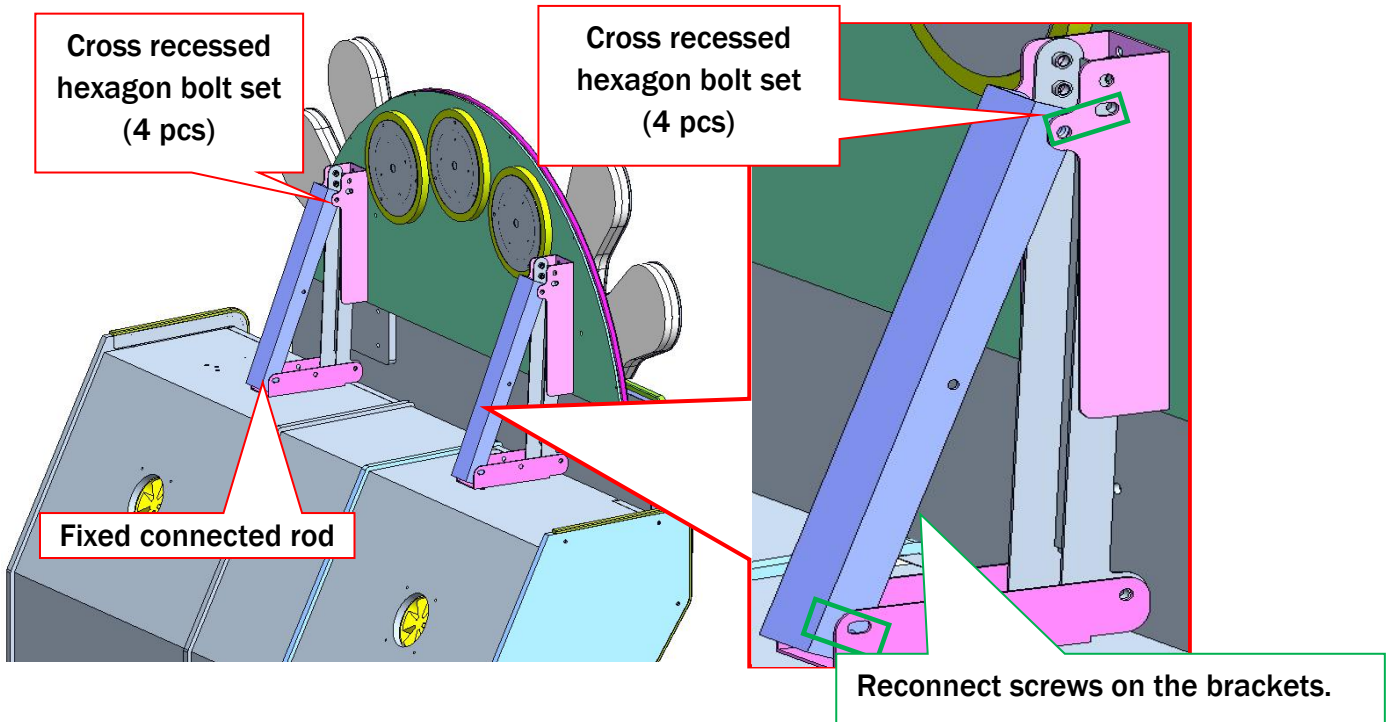

Step 11 Add ball to each lane and apply power.

Step 12 Once game is powered on and operational place it in position. Utilizing the leg levelers to assure the back box and lanes are level with each other.

Finish!

4.5 Card Reader Installation Safety Notice

 Take precaution to assure that all wiring voltages are confirmed prior to installation of card reader. All warranties are void if not properly installed resulting in logic board damage.

Important: This game is pre-wired to AAMA standards. It is highly recommended to utilize this wiring for Card reader installation.

4.6 Voltage Conversion

Step 1 Power off the machine. Locate the Power supply.

Step 2 Toggle the Power supply and PC switch to 115V or 230V according to your need.

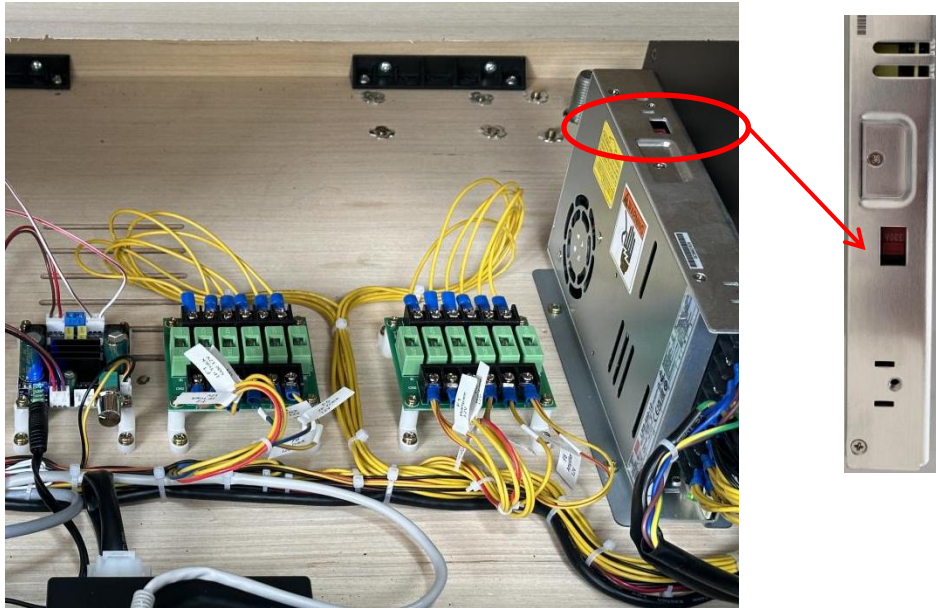

Step 3 Locate Power box. Replace fuse.



Step 4 Locate lane side. Utilize key to open side door,

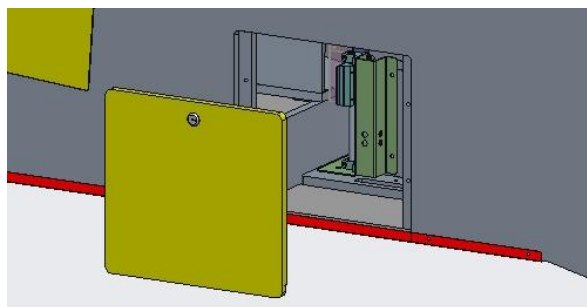

Step 5 Loosen swing screw. Unplug the connectors and take Send ball assembly out.

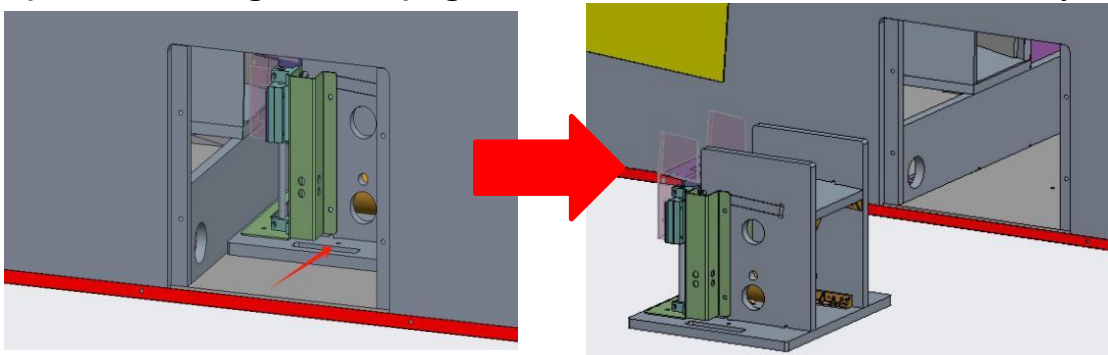

Step 6 Loosen hexagon screw as shown below.

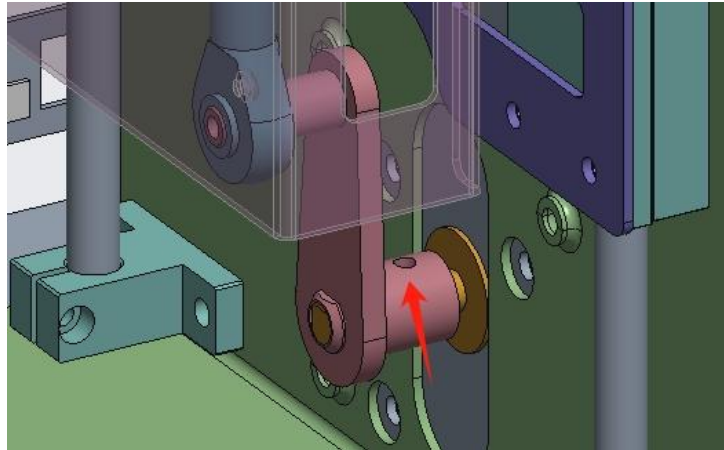

Step 7 Loosen 4 screws to remove motor set.

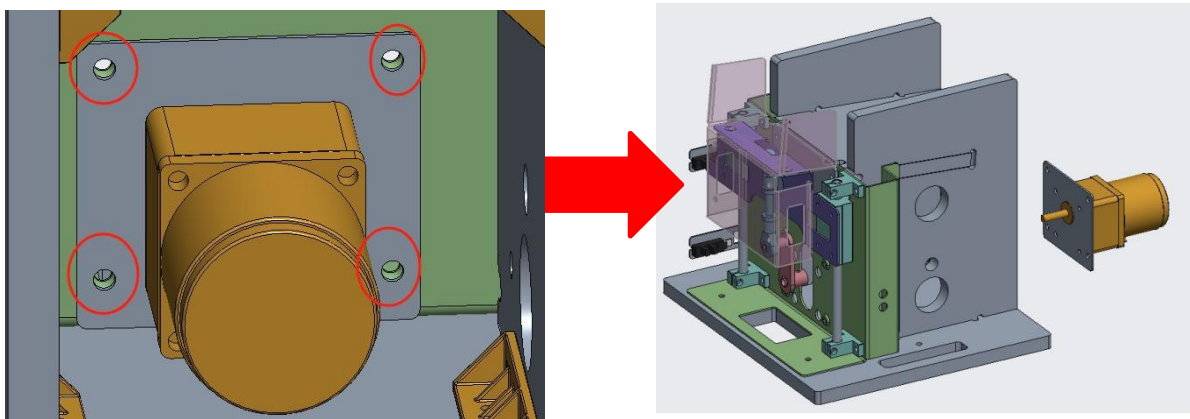

Step 8 Loosen 4 screws to remove motor .

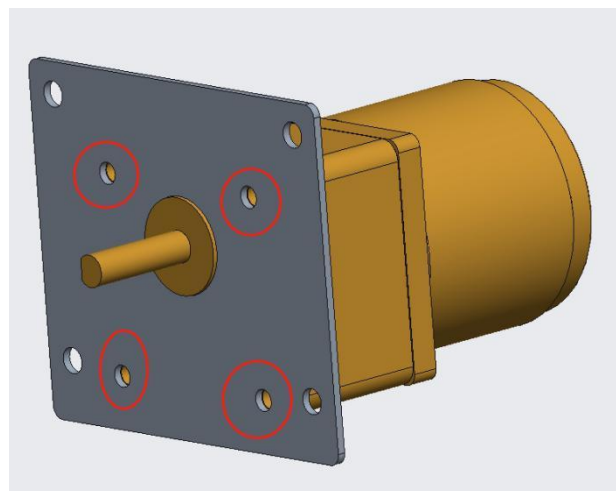

Step 9 Replace it with new motor(suitable voltage) and install in reversed order.

5. HOW TO PLAY

5.1 Insert coins/tap/swipe card to play.



Roll the ball down to the lane and hit pins to get points.



5.2 Hit Power Up pins to get Power ups!



5.3 Power ups are automatically activated. Try them all!

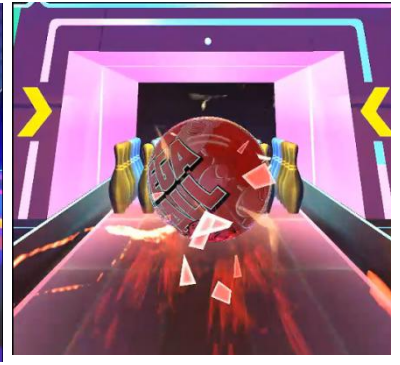
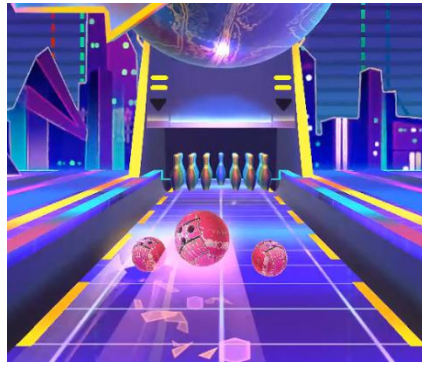

5.4 Hits as many pins as possible! Strikes earn bonus points!



5.5 Win Power Ball. You can scan the power ball bar code on the machine scanner. After scanning will be equip Power ball and play it during the game..

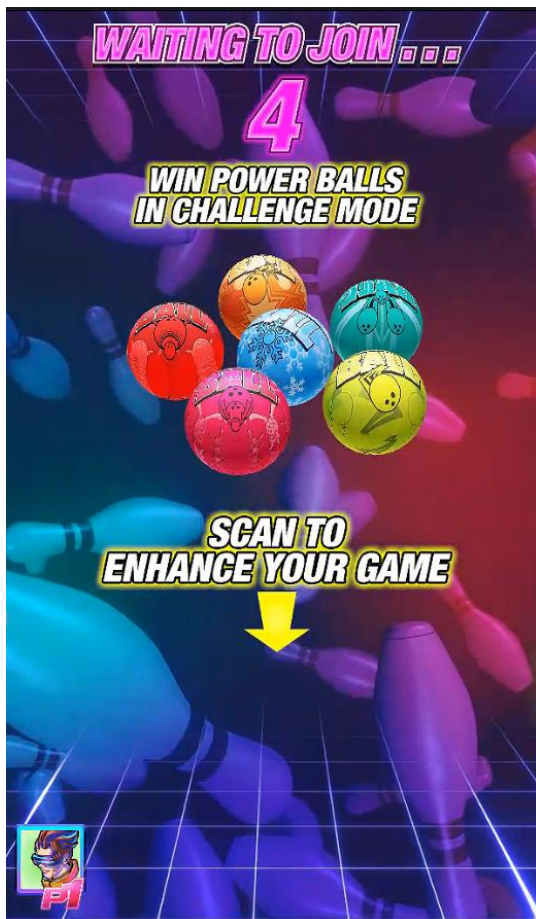

5.6 Game Scene:



6. GAME OPTION

6.1 Adjustment button instruction

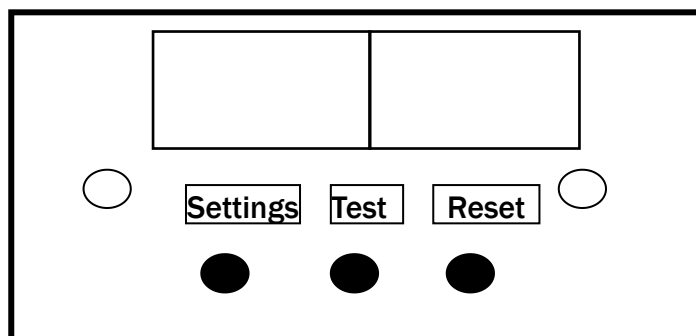

Open the coin door and there is a meter panel. Press Settings button to enter into the setting menu.

6.2 Setting menu

6.2.1 Main menu

Options
Basic Setting
Customized Setting
Input Test
Output Test
Light Setting
Sensor Test
Scanner Test

Options
Game Reset
Date/Time Setting
Language/语言
About This Game
Bookkeeping
Daily Record
Back to game

6.2.2 Basic Setting

Options	Adjustment Value	Default
Free Play	OFF_ON	OFF
Ticket(s) Out	OFF_ON	ON
Power Ball Switch	OFF_ON	ON
Out Of Ticket(s)	Store in memory_Call Attendant	Store in memory
Demo Music	OFF_ON	ON
Memory Save	OFF_ON	ON
Volume	1-10	7
BGM Volume	1-10	5
SE Volume	1-10	4
VO Volume	1-10	3
Coins Per Game	1-10	1
Pay Mode	Insert Coins_Tap/Swipe Card_Insert Coins & Tap/Swipe Card	Insert Coins

6.2.3 Customized Setting

Please set the PC Number to link machines.

Options	Adjustment Value	Default	Description
Regulation Mode	OFF_ON		Refill ball
Play mode	Single Player Pro Mode_2 Lanes Linking	2 Lanes Linking	
PC Number	1-3	3	
Multiplayer Join Time	5-20	5	
Power Ball Scanning	OFF_ON	ON	
Game Round	3-6	3	
1 Wave Pins	10-200	10	
2 Waves Pins	10-200	20	
3 Waves Pins	10-200	40	
4 Waves Pins	10-200	80	
5 Waves Pins	10-200	160	
6 Waves Pins	10-200	200	
Golden Ball Game	OFF_ON	ON	
Strikes Golden Ball Points	1-3	2	
Power Pins	OFF_ON	ON	
Divided By 2	OFF_ON	ON	
Fixed Ticket(s) Mode	OFF_ON	OFF	
Fixed Ticket(s)	0-300	6	
Score per Ticket(s)	1-1000	50	
Score Per Power Ball	1-1000	300	
Bumper Version	OFF_ON	ON	
No Ball Found	OFF_ON	ON	
Inhibit Timing	1-60	15	
Back&Save			
Back			

6.2.4 Input Test

Options	Adjustment Value
Power Ball Saving Sensor	OFF_ON
Power Ball Diving Sensor	OFF_ON
1P Coin	OFF_ON
1P Power Ball Drop Sensor	OFF_ON
1P Power Ball Out Sensor	OFF_ON
1P Power Ball Detect Sensor	OFF_ON
1P Ball Detect	OFF_ON
1P Ball Signal	OFF_ON
1P Send Ball Error	OFF_ON
2P Coin	OFF_ON
2P Power Ball Drop Sensor	OFF_ON
2P Power Ball Out Sensor	OFF_ON
2P Power Ball Detect Sensor	OFF_ON
2P Ball Detect	OFF_ON
2P Ball Signal	OFF_ON
2P Send Ball Error	OFF_ON
Back	

6.2.5 Output Test

Options
1P Ball Release Test
1P Ticket Test
1P Power Ball Test
1P Bowling Ball Exit Light
2P Ball Release Test
2P Ticket Test
2P Power Ball Test
2P Bowling Ball Exit Light
Back

Options	Adjustment Value
Clear Owed Ticket	OFF_ON
Clear Power Ball	OFF_ON
Clear Unused Coin	OFF_ON
Back	

6.2.10 Date/Time Setting

Options
Year
Month
Day
Hour(24)
Minute
Second
Back&Save
Back

6.2.11 About This Game

Options
CPU
Motherboard
HDD
RAM
Display Adapter
Monitor
Screen
Version
Press Any Button On The Counter To Back

6.2.12 Bookkeeping

Player	Coins	Power Ball	Power Ball Payout	Tickets	Payout
These Settings Are Non-Resettable					
Back					

6.2.13 Daily Record

Date	Weekday	Runtime	Coins	Power Ball	Power Ball Payout	Tickets	Payout
Clear Back							





7. TROUBLESHOOTINGS



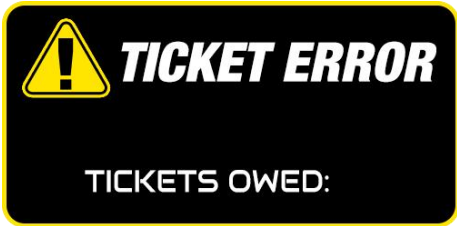

7.1 Common Problem

Please confirm that all connectors fit tightly.

Symptom	Possible Cause	Recommended action
Game will not start	Frame assembly connector is loose.	Check connector.
	Frame assembly fault	Contact with UNIS Service.
Power off	Circuit protector make power SW in off state.	Turn on power SW again. If appeared again and again, machine has anomaly. Please contact with UNIS Service.
Card reader not working	The connector is loose.	Check connector.
	Card reader fault.	Check with card reader manufacturer.
No ticket dispensing	Out of ticket.	Add ticket and press reset button
	Ticket jamming.	Remove the jammed tickets and press reset button.
	The connector is loose.	Plug the connector tightly.
No sound	Low volume	Raise the volume.
	Connector loose.	Check connector.
	Speaker fault.	Check speaker.
	POT installation error.	Install POT correctly.
	POT fault.	Change POT.
	Audio cable problem.	Reconnect the audio cable or change it.

If you see following error signs showing on the display, please try the recommended action.

Display	Possible Cause	Recommended action
	The connection part of the IO board and PC are loose.	Check and reconnect the loose ports of the PC or IO board.
	Cable quality problem	Change the cable after checking the connection between IO board and PC.
	Cable became loose during transportation.	Check and reconnect the loose cables of the PC or IO board.
	IO board is faulty.	Reboot the game after checking U disk connection and cable problem, if the problem remains unresolved, please call the service department for assistance.
	Out of ticket.	Refill ticket
	Loose connection of the ticket dispenser's cables.	Check and reconnect the loose cables to the ticket dispenser.
	Ticket dispenser is faulty.	Change the ticket dispenser.
	Ticket jam.	Remove jammed tickets.
	Out of ticket.	Refill tickets and press reset button.
	Loose connection of the send ball assembly.	Check and reconnect the loose cables of send ball assembly.
	Send ball assembly is broken.	Check the connection, if the problem remains unresolved, please call the service department for assistance.

Display	Possible Cause	Recommended action
 SENSOR ERROR	Loose connection to the sensor's cables.	Loose connection to the sensor's cables.
	Check and reconnect the	Check and reconnect the
 NO BALL FOUND	No ball found inside the lane.	Roll a ball to the lane.
	Sensor problem.	Change the sensor after checking the connection.
 NETWORK ERROR, PLEASE CHECK BELOW: 1. CHECK IF PC LINK NUMBER IS SET CORRECTLY IN CUSTOMIZED SETTING. 2. CHECK IF NETWORK PORT AND NETWORK CABLE OPERATED PROPERLY. 3. CHECK IF CONNECTED MACHINES ARE POWERED UP PROPERLY.	Wrong PC Number	Set the unique PC Number for each machine.
	Bad connection of the network port or cable.	Check if the network port is lighting or replace the network cable light.
	Switch or network problem	Check the power of the switch or replace the switch. Make sure the internet connection is available.
 POWER BALL ERROR POWER BALL OWED:	No power ball	Refill power ball to the hopper.
	Power ball jam.	Remove jammed balls.
	Loose connection of the Hopper cables.	Check and reconnect the loose cables to the Hopper.
	Hopper is faulty.	Replace hopper
 POWER BALL ERROR CALL ATTENDANT POWER BALL OWED:	No power ball	Refill power ball to the hopper.

7.2 System Recovery Operation **(NOTE: Do not disconnect power during this process.)**

1. Turn off the game. Remove recovery stick from the machine. (Note: This process may take up to 60 minutes) Insert the recovery stick into the port at the back of the computer.
2. Restart PC to enter the system recovery screen as shown.

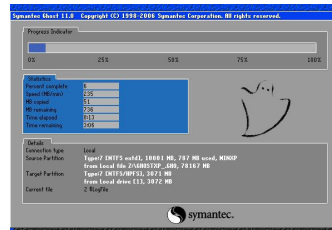

3. The game will automatically start recovery.
4. Once system recovery is partially finished (as shown below), and the ICON appears, remove the recovery stick from the computer. The game will continue the install process.

OK to remove the recovery stick.



5. Assure that the recovery stick has been properly secured for future use.



WARNING: The recovery stick should only be used to fix software errors. Using it for other purposes may cause unexpected results and damages.

8. MAINTENANCE & INSPECTION

8.1 Safety Check

Check the points listed before operating the machine. These checks are necessary for safe machine operation:

1. Test game before operation each day.
2. Conduct monthly routine checks of game components to ensure good working condition.
3. Check the machine regularly for dust and clean when necessary.

Note: Parts and components require preventative maintenance to maintain proper operation.

8.2 Handling Precautions

When installing or inspecting the machine, be very careful and pay attention to ensure that the player can enjoy the game safely.

Inappropriate handling running counter to the cautionary matters can cause personal injury or damage to the machine.



NOTICE

We do not recommend using power tools as they may cause damage.

8.3 Linking setting

Kits for linking

No	Name	Qty	Picture	Note
1	Network cable(5M)	3		For two sets linking
2	Switch	1		For three sets linking

For two sets linking:

Step 1 For two sets linking, please connect the network ports of two machines with Network cable(5M).

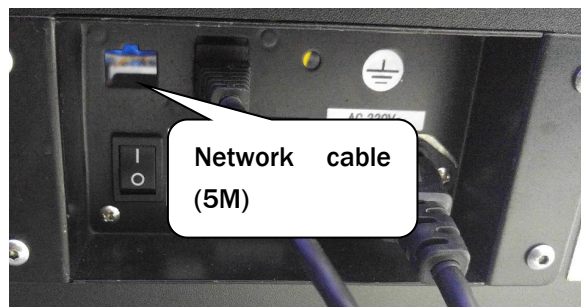

Step 2 Please make sure the software is the same between 2 machines.

Step 3 Enter into Setting menu

→Customized setting

→PC Number

Machine	PC Num
A	1
B	2

Step 4 Enter into Setting menu

→Customized setting

→Play mode

→**4 lanes linking**

Machine	Play mode
A	4 lanes linking
B	4 lanes linking

Finish !

For three sets linking:

Step 1 For three sets linking, please connect the Network cable (5M) to the network port on the power outlet.

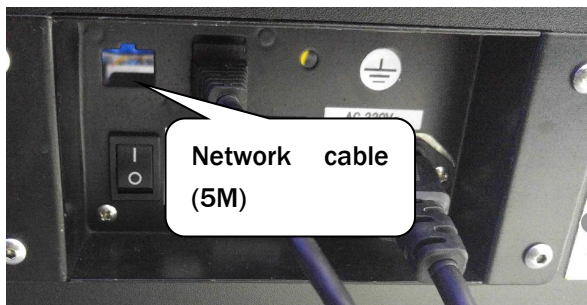

Step 3 Please make sure the software is the same between 3 machines.

Step 4 Enter into Setting menu
 →Customized setting
 →PC Number

Machine	PC Num
A	1
B	2
C	3

Step 2 For three machines linking, please connect all the network cables (5M) to the switch and plug in the power cord.(Switch provided by user)

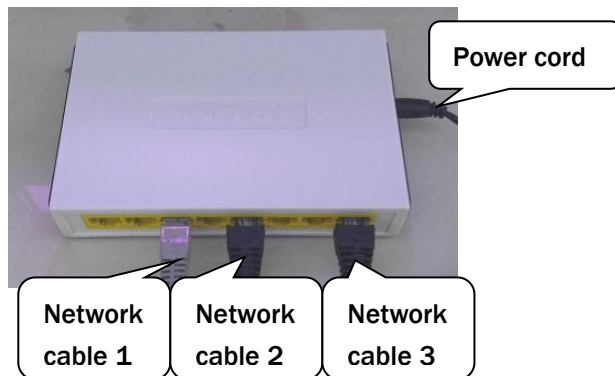

Step 5 Enter into Setting menu
 →Customized setting
 →Play mode
 →**6 lanes linking**

Machine	Play mode
A	6 lanes linking
B	6 lanes linking
C	6 lanes linking

Finish !

Display signal for reference:

	<p>NETWORK ERROR, PLEASE CHECK THE FOLLOWING....</p> <ol style="list-style-type: none"> 1. CHECK PC NUMBER IS SET IN CUSTOMIZED SETTING. 2. CHECK NETWORK PORT AND NETWORK CABLE IS OPERATED PROPERLY. 3. CHECK CONNECTED MACHINES ARE POWERED UP PROPERLY
	<p>CONNECTION IS SUCCESSFUL</p>

9. OVERALL CONSTRUCTION

9.1 General Assembly

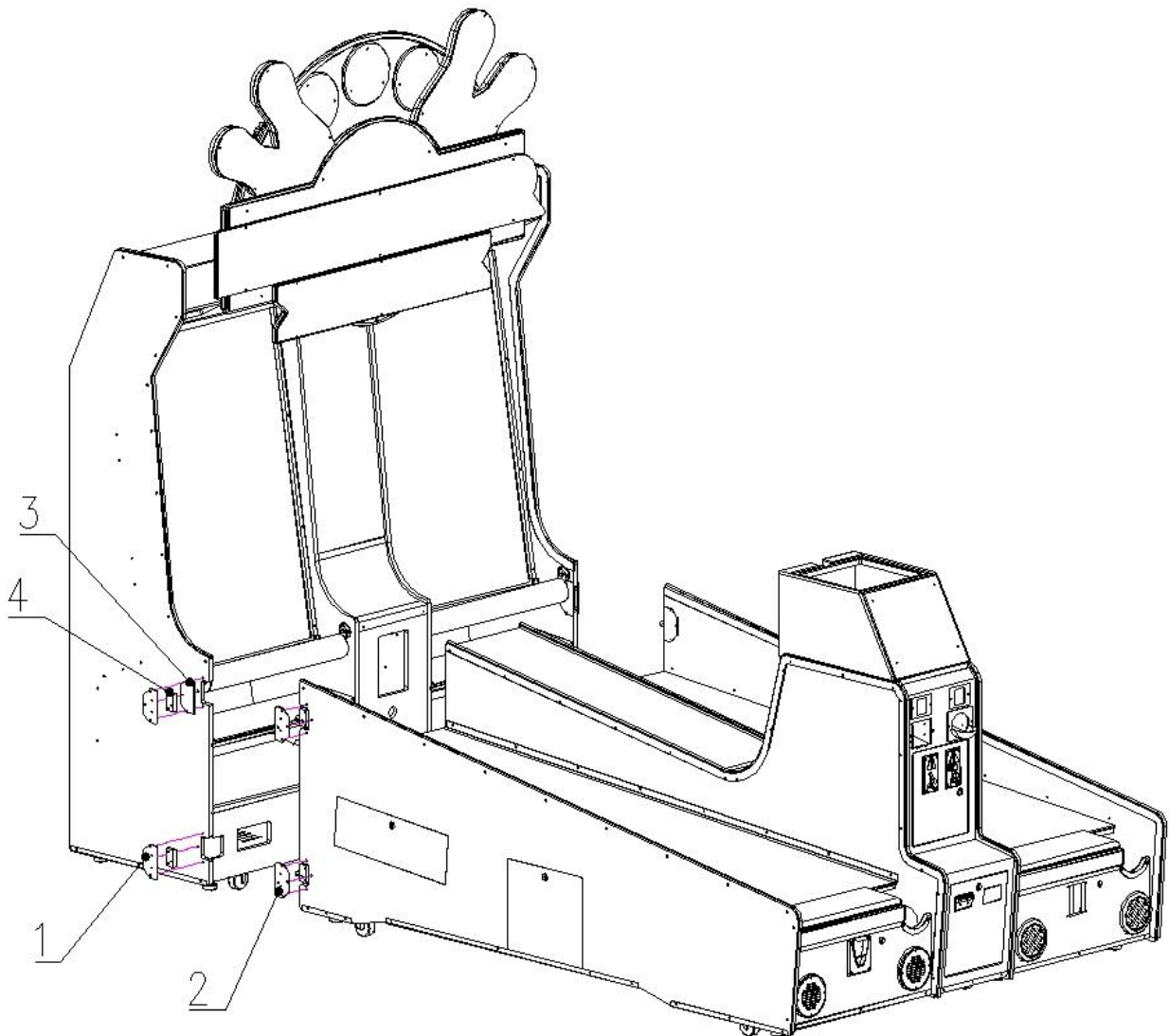

No.	Part No.	Code No.	Name	Version	Qty
1	L129-0001-00	202.1.2304.170	Monitor lock pin plate	V1.1	4
2	L129-0002-00	202.1.2304.171	Lane lock pin plate	V1.1	4
3	L129-0003-00	202.1.2304.172	Inner side lock pin	V1.1	4
4	L129-0004-00	2.53.00000148	Buckle	V1.1	4

9.2 Monitor Wooden Frame

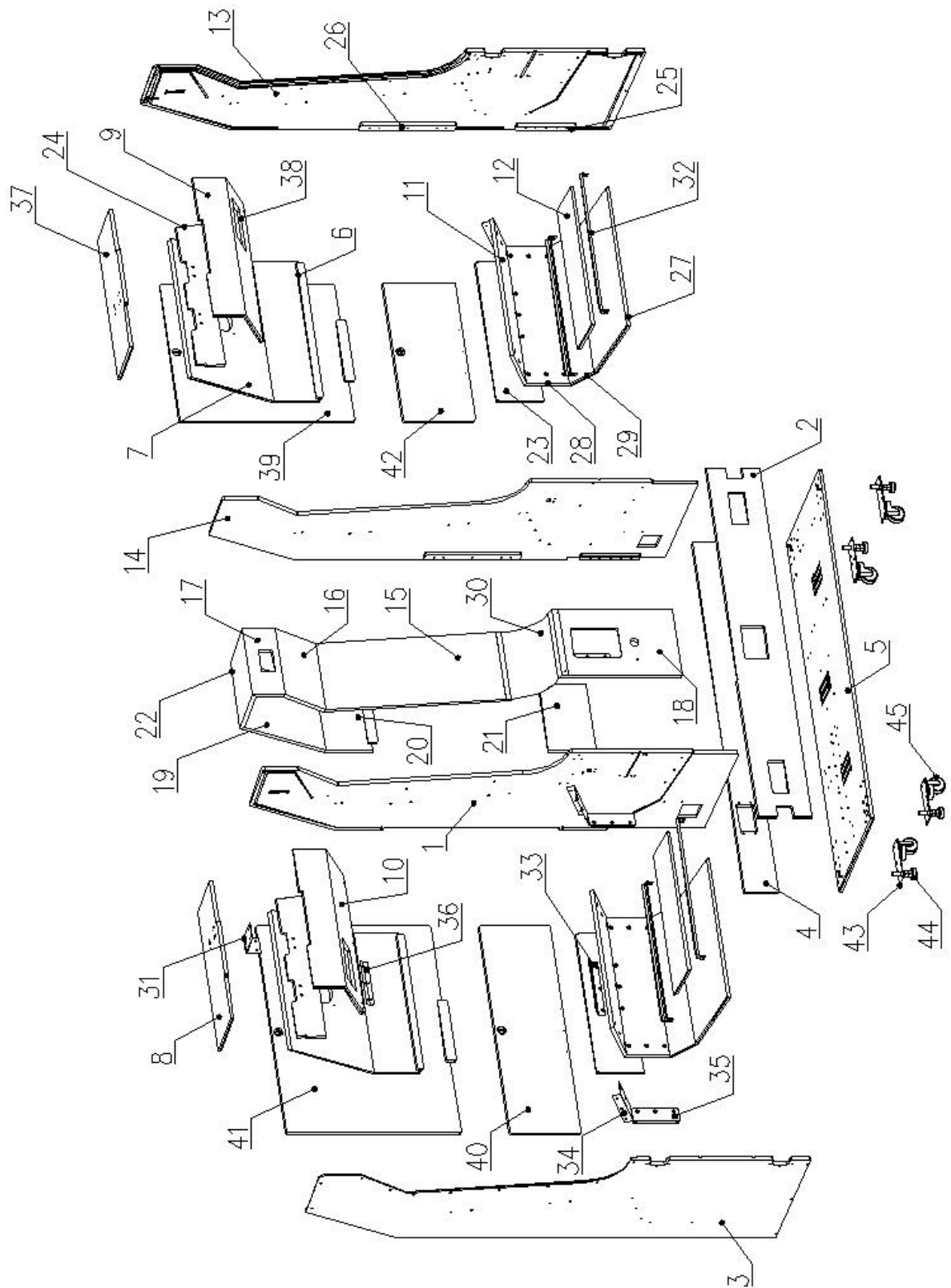

No.	Part No.	Code No.	Name	Version	Qty
1	L129-0102-00	203.1.2304.001	Inner L side board	V1.1	1
2	L129-0103-00	203.1.2304.002	Front bottom blanking board	V1.1	1
3	L129-0104-00	203.1.2304.003	Outer L side board	V1.1	1
4	L129-0105-00	203.1.2304.004	Power supply board	V1.1	1
5	L129-0106-00	203.1.2304.006	Monitor base board	V1.1	1
6	L129-0107-00	203.1.2304.009	Back upper board	V1.1	2
7	L129-0108-00	203.1.2304.010	Fan board	V1.1	2
8	L129-0109-00	203.1.2304.011	L top board	V1.1	1
9	L129-0110-00	203.1.2304.012	Front up board	V1.1	2
10	L129-0111-00	203.1.2304.013	Front mid board	V1.1	1
11	L129-0112-00	203.1.1605.031	Back lane back board	V1.1	2
12	L129-0113-00	203.1.2304.017	Back lane board	V1.1	2
13	L129-0114-00	203.1.2304.018	Outer R side board	V1.1	1
14	L129-0115-00	203.1.2304.019	Inner R side board	V1.1	1
15	L129-0116-00	203.1.2304.020	Tri-pin board	V1.1	1
16	L129-0117-00	203.1.2304.021	Mid up connect board	V1.1	1
17	L129-0118-00	203.1.2304.022	Marquee wiring board	V1.1	1
18	L129-0119-00	203.1.2304.024	Mid bottom connect board	V1.1	1
19	L129-0120-00	203.1.2304.008	Back mid up connect board	V1.1	1
20	L129-0121-00	203.1.2304.023	Back mid bottom connect board	V1.1	1
21	L129-0122-00	203.1.2304.025	Upper door board bottom board	V1.1	1
22	L129-0123-00	203.1.2304.026	Mid top connect board	V1.1	1
23	L129-0124-00	203.1.2304.027	Bottom door board bottom board	V1.1	2
24	L129-0125-00	203.1.2304.028	Top strengthen board	V1.1	2
25	L129-0126-00	203.1.1605D.010	Door position board	V1.1	4
26	L129-0127-00	203.1.1605D.011	Upper door position board	V1.1	4
27	L129-0128-00	203.1.1605D.004	Back lane base board	V1.1	2
28	L129-0129-00	203.1.1605.032	lane tail board	V1.1	2
29	L129-0130-00	203.1.1605.033	lane tail board	V1.1	2
30	L129-0131-00	202.1.2304.173	Marquee arc plate	V1.1	1
31	L129-0132-00	202.1.2304.174	Marquee strengthen plate	V1.1	2
32	L129-0133-00	202.1.2304.176	lane strengthen plate	V1.1	4
33	L129-0134-00	202.1.1605.061	Connect plate	V1.1	2
34	L129-0135-00	202.1.1605.003	Back R lane strengthen plate	V1.1	4
35	L129-0136-00	202.1.1605.004	Back R lane strengthen plate 2	V1.1	4
36	L129-0137-00	202.1.2304.175	Mid connect plate	V1.1	2
37	L129-0138-00	203.1.2304.014	R top board	V1.1	1
38	L129-0139-00	203.1.2304.102	R front mid board	V1.1	1
39	L129-0140-00	203.1.2304.005	Upper door board(short)	V1.1	1
40	L129-0141-00	203.1.2304.007	Bottom door board(long)	V1.1	1
41	L129-0142-00	203.1.2304.015	Upper door board(long)	V1.1	1
42	L129-0143-00	203.1.2304.016	Bottom door board(short)	V1.1	1
43	L129-0144-00	2.60.00010000	Caster bracket	V1.1	4
44	L129-0146-00	2.60.00008000	Cabinet leveller	V1.1	4
45	L129-0147-00	2.55.01.000056	2.5" caster	V1.1	4

No.	Part No.	Code No.	Name	Version	Qty
1	L129-0151-00	202.1.2304.177	Monitor mounting plate	V1.1	4
2	L129-0152-00	202.1.2304.178	Monitor fixing plate	V1.1	8
3	L129-0153-00	202.1.2304.179	Monitor cover plate(horizontal)	V1.1	2
4	L129-0154-00	202.1.2304.180	Monitor side plate	V1.1	2
5	L129-0155-00	206.1.2304.118	Monitor cover plate	V1.1	2
6	L129-0156-00	202.1.2304.181	Buffer plate	V1.1	4
7	L129-0157-00	202.1.2304.182	Monitor lane pressing plate	V1.1	4
8	L129-0158-00	202.1.2304.183	Monitor bottom plate	V1.1	2
9	L129-0159-00	202.1.2304.184	Buffer swing rod	V1.1	4
10	L129-0160-00	206.1.2304.119	L monitor side plastic 1	V1.1	1
	L129-0161-00	206.1.2304.120	L monitor side plastic 2	V1.1	1
	L129-0162-00	206.1.2304.121	L monitor side plastic 3	V1.1	1
	L129-0163-00	206.1.2304.122	L monitor side plastic 4	V1.1	1
	L129-0164-00	206.1.2304.123	L monitor side plastic 5	V1.1	1
11	L129-0165-00	202.1.2304.185	Monitor L side pressing plate	V1.1	1
12	L129-0166-00	206.1.2304.124	Monitor plate(v)	V1.1	4
13	L129-0167-00	206.1.1605.011	Buffer foam 1	V1.1	2
14	L129-0168-00	206.1.2304.126	Monitor foam	V1.1	4
15	L129-0169-00	206.1.2304.127	lane back plastic	V1.1	2
16	L129-0170-00	206.1.2304.128	R monitor side plastic 1	V1.1	1
	L129-0171-00	206.1.2304.129	R monitor side plastic 2	V1.1	1
	L129-0172-00	206.1.2304.130	R monitor side plastic 3	V1.1	1
	L129-0173-00	206.1.2304.131	R monitor side plastic 4	V1.1	1
	L129-0174-00	206.1.2304.132	R monitor side plastic 5	V1.1	1
17	L129-0175-00	202.1.2304.186	Monitor R side pressing plate	V1.1	1
18	L129-0177-00	202.1.2304.188	Position plate	V1.1	8
19	L129-0182-00	202.1.2304.187	Monitor side cover plate	V1.1	4
20	L129-0183-00	202.1.1605.056	Protect tube	V1.1	2
21	L129-0184-00	299.1.1605.003A	Protect tube foam	V1.1	2
22	L129-0185-00	202.1.1605.016	Foam fixing plate	V1.1	2
23	L129-0186-00	202.1.1605.017	Foam pressing plate	V1.1	4

Monitor assembly back side:

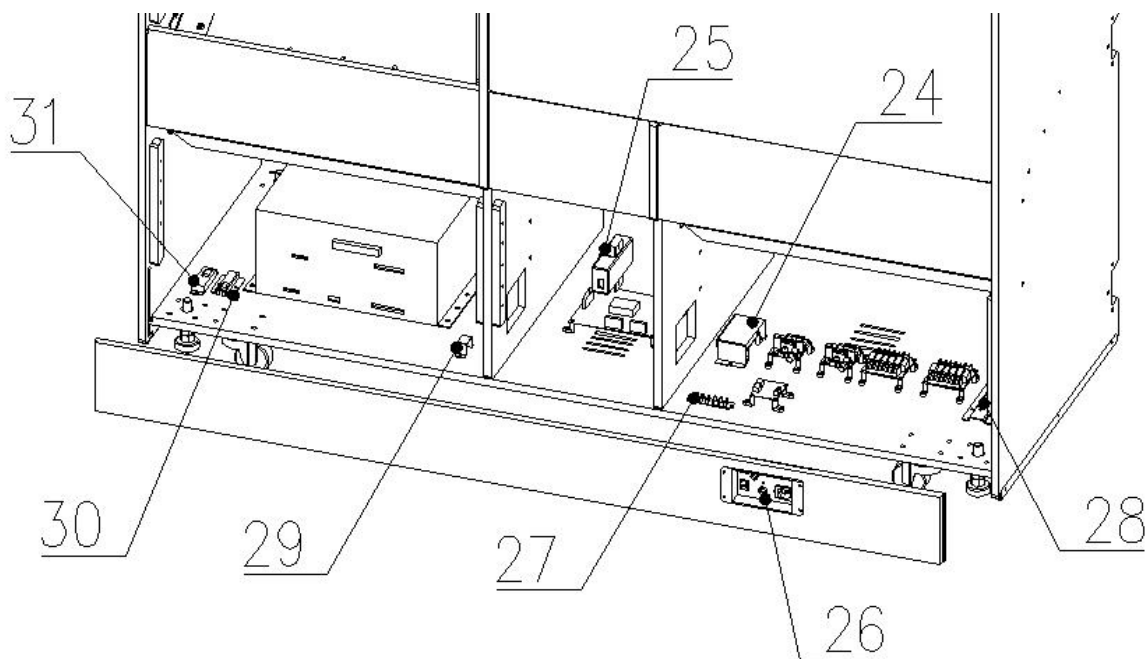

No.	Part No.	Code No.	Name	Version	Qty
24	L129-0176-00	206.1.1901.025	Protect cover	V1.1	1
25	L129-0187-00	202.1.1605.043	Power supply plate	V1.1	1
26	L129-0190-00	2.60.00042001B	Wiring box	V1.1	1
	L129-0191-00	2.60.00042002B	Wiring box cover	V1.1	1
27	L129-0192-00	202.4.2209.078	GND plate	V1.1	1
28	L129-0193-00	202.4.2002.045	Power plate	V1.1	1
29	L129-0194-00	202.1.1707.041	Pressing plate	V1.1	1
30	L129-0195-00	2.60.00055000	Dongle plate	V1.1	1
31	L129-0196-00	2.60.00064000	Recovery stick plate	V1.1	1

9.4 Sensor Frame

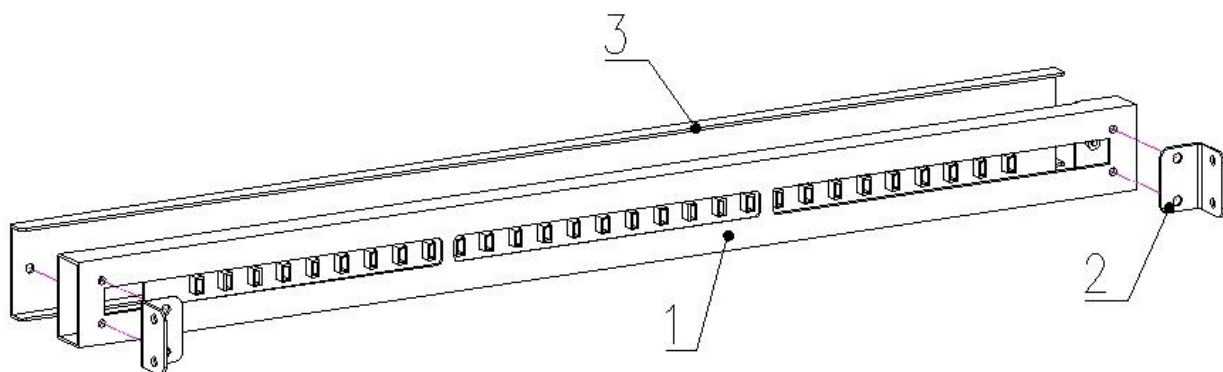

No.	Part No.	Code No.	Name	Version	Qty
1	L129-0179-00	202.1.2304.189	Monitor sensor frame	V1.1	1
2	L129-0180-00	202.1.2304.190	Monitor sensor connect plate	V1.1	2
3	L129-0181-00	202.1.2304.191	Monitor sensor plate	V1.1	1

9.5 L Lane Assembly

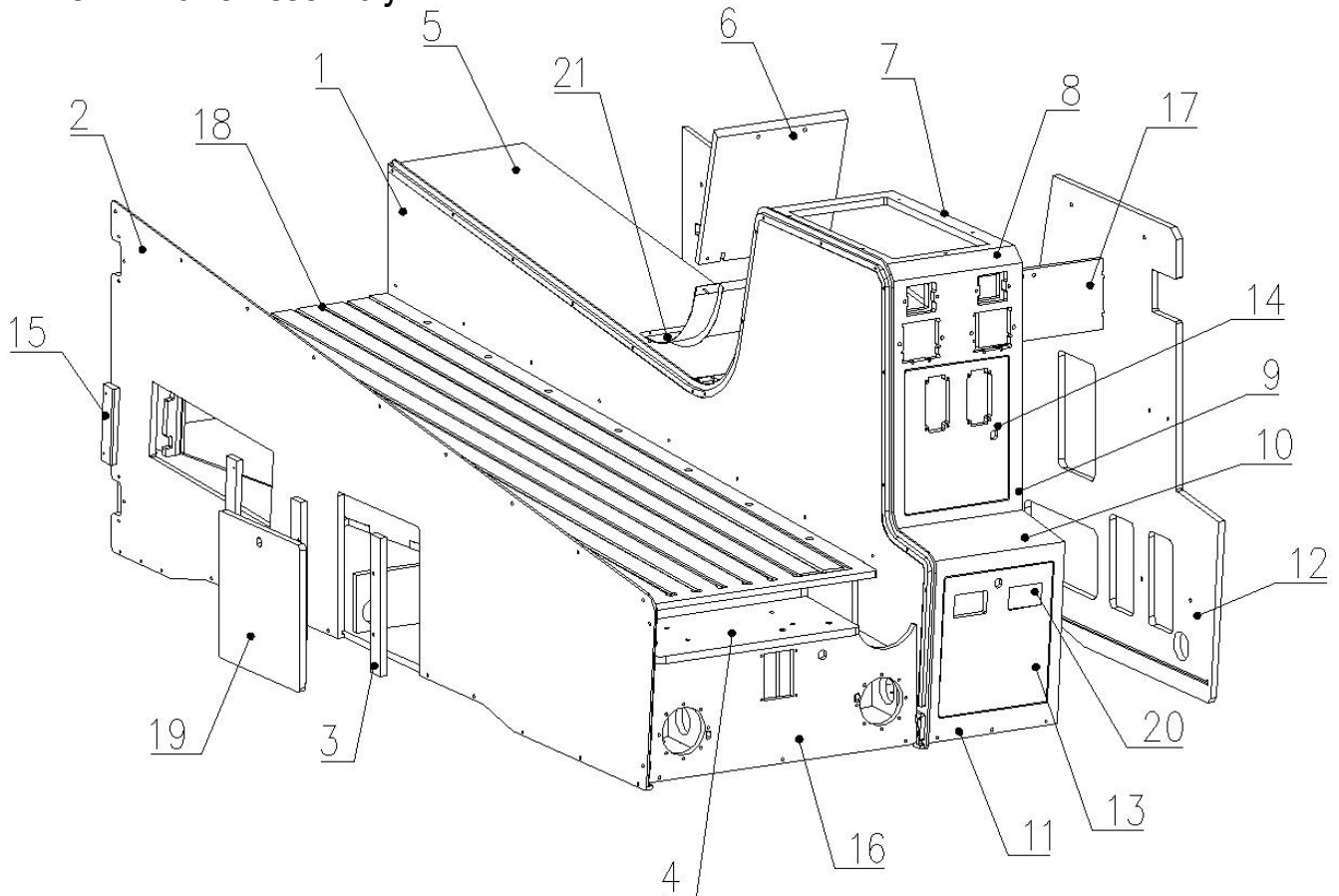

No.	Part No.	Code No.	Name	Version	Qty
1	L129-0202-00	203.1.2304.029	L lane middle board	V1.1	1
2	L129-0204-00	203.1.2304.031	L lane L side board	V1.1	1
3	L129-0209-00	203.1.2304.038	Door fixing board	V1.1	2
4	L129-0211-00	203.1.2304.044	Front light support board	V1.1	1
5	L129-0216-00	203.1.2304.049	Up front connect board	V1.1	1
6	L129-0217-00	203.1.2304.052	Back connect board	V1.1	1
7	L129-0218-00	203.1.2304.053	Ball decoration board	V1.1	1
8	L129-0219-00	203.1.2304.054	Small connect board	V1.1	1
9	L129-0220-00	203.1.2304.055	Coin board	V1.1	1
10	L129-0221-00	203.1.2304.056	Front connect board	V1.1	1
11	L129-0222-00	203.1.2304.057	Ticket board	V1.1	1
12	L129-0224-00	203.1.2304.059	L lane R side board	V1.1	1
13	L129-0225-00	203.1.2304.061	Ticket door board	V1.1	1
14	L129-0226-00	203.1.2304.062	Coin door board	V1.1	1
15	L129-0233-00	203.1.2304.037	Drawing fixing board	V1.1	2
16	L129-0240-00	203.1.2304.043	Speaker fixing board	V1.1	1
	L129-0252-00	2.63.00.000011	4" hinge	V1.1	2
17	L129-0241-00	203.1.2304.042	Support board	V1.1	1
18	L129-0243-00	203.1.2304.035	lane board	V1.1	1
19	L129-0244-00	203.1.2304.060	Ball out cover board	V1.1	1
20	L129-0245-00	203.1.2304.064	DBV cover board	V1.1	2
21	L129-0246-00	202.1.2304.192	Back arc plate	V1.1	1

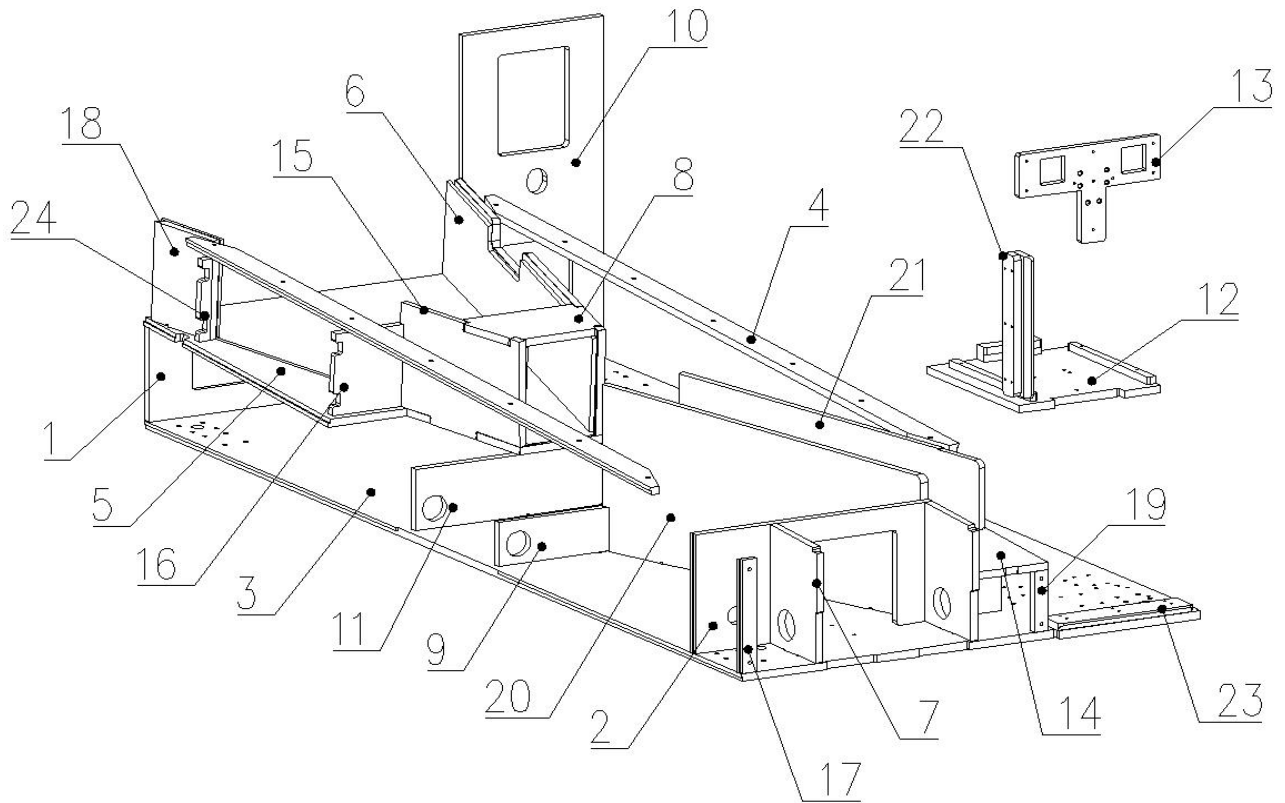

No.	Part No.	Code No.	Name	Version	Qty
1	L129-0203-00	203.1.2304.030	lane back blanking board	V1.1	1
2	L129-0205-00	203.1.2304.032	lane blocking board	V1.1	1
3	L129-0206-00	203.1.2304.033	L lane front base board	V1.1	1
4	L129-0207-00	203.1.2304.034	Panel connect board	V1.1	2
5	L129-0208-00	203.1.2304.036	L bottom lane front board	V1.1	1
	L129-0247-00	206.1.2304.133	lane bottom foam	V1.1	1
6	L129-0210-00	203.1.2304.041	L bottom lane front side board	V1.1	1
	L129-0248-00	206.1.2304.134	lane long buffer foam	V1.1	1
7	L129-0212-00	203.1.2304.045	Ball slot side board	V1.1	2
8	L129-0213-00	203.1.2304.046	lane connect board	V1.1	1
9	L129-0214-00	203.1.2304.047	Small fence board	V1.1	1
10	L129-0215-00	203.1.2304.048	Back mid blanking board	V1.1	1
11	L129-0223-00	203.1.2304.058	Large fence board	V1.1	1
12	L129-0227-00	203.1.2304.063	Coin box bottom board	V1.1	1
13	L129-0228-00	203.1.2304.065	Coin strengthen board	V1.1	1
14	L129-0229-00	203.1.2304.068	Ball board	V1.1	1
15	L129-0230-00	203.1.2304.070	Side fence board(long)	V1.1	1
	L129-0250-00	206.1.2304.136	lane side front foam	V1.1	1
16	L129-0231-00	203.1.2304.071	Drawer long strengthen board	V1.1	1
17	L129-0232-00	203.1.2304.066	Speaker L fixing board	V1.1	1
18	L129-0234-00	203.1.2304.069	L side short board	V1.1	1
	L129-0249-00	206.1.2304.135	lane side back foam	V1.1	1
19	L129-0235-00	203.1.2304.067	Speaker R fixing board	V1.1	1
20	L129-0236-00	203.1.2304.039	Sliding L side board	V1.1	1
21	L129-0237-00	203.1.2304.040	Sliding R side board	V1.1	1
22	L129-0238-00	203.1.2304.050	Door position board	V1.1	1
23	L129-0239-00	203.1.2304.051	Hinge mounting board	V1.1	2
24	L129-0242-00	203.1.2304.072	Drawer short strengthen board	V1.1	1

9.6 R Lane Assembly

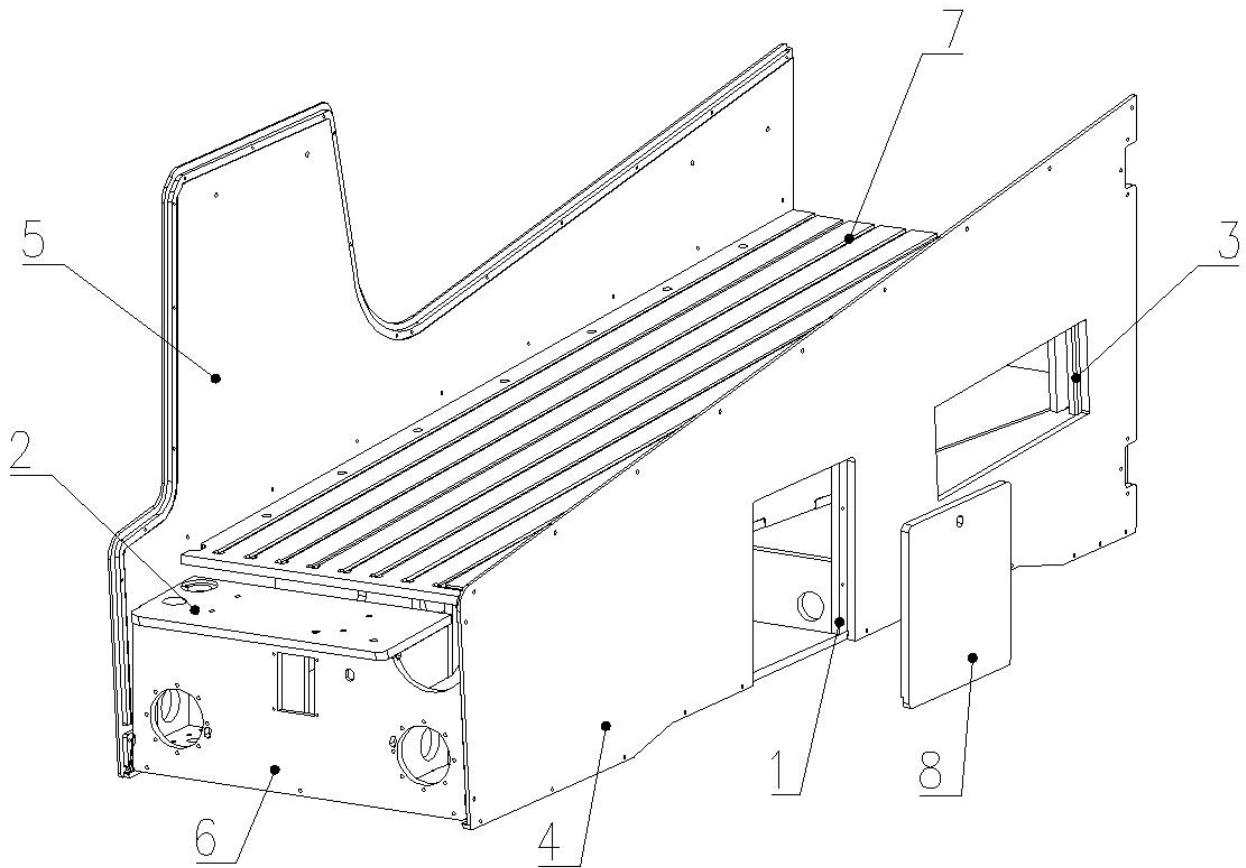

No.	Part No.	Code No.	Name	Version	Qty
1	L129-0209-00	203.1.2304.038	Door fixing board	V1.1	2
2	L129-0211-00	203.1.2304.044	Front light support board	V1.1	1
3	L129-0233-00	203.1.2304.037	Drawing fixing board	V1.1	2
4	L129-0261-00	203.1.2304.075	R lane R side board	V1.1	1
5	L129-0262-00	203.1.2304.074	R lane L side board	V1.1	1
6	L129-0240-00	203.1.2304.043	Speaker fixing board	V1.1	1
7	L129-0243-00	203.1.2304.035	lane board	V1.1	1
8	L129-0244-00	203.1.2304.060	Ball out cover board	V1.1	1

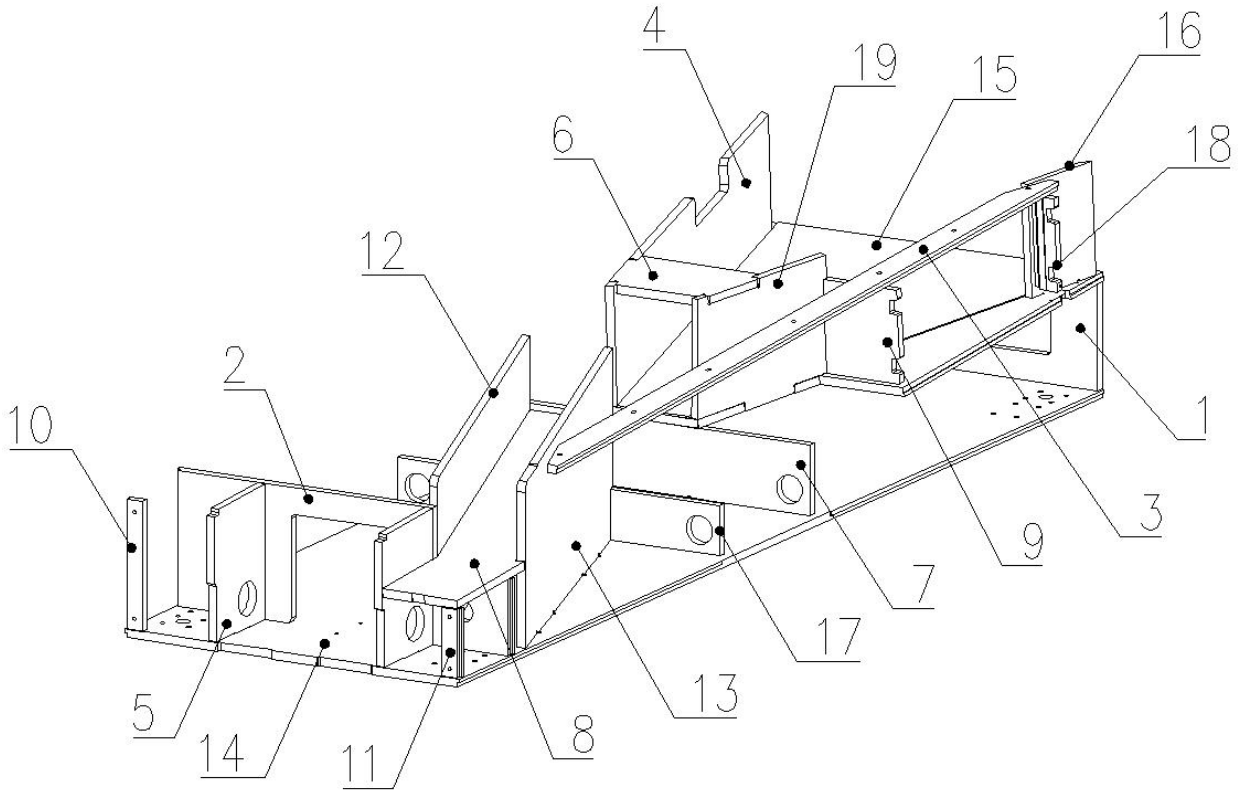

No.	Part No.	Code No.	Name	Version	Qty
1	L129-0203-00	203.1.2304.030	lane back blanking board	V1.1	1
2	L129-0205-00	203.1.2304.032	lane blocking board	V1.1	1
3	L129-0207-00	203.1.2304.034	Panel connect board	V1.1	2
4	L129-0255-00	203.1.2304.077	R bottom lane front side board	V1.1	1
	L129-0268-00	206.1.2304.188	lane long buffer foam	V1.1	1
5	L129-0212-00	203.1.2304.045	Ball slot side board	V1.1	2
6	L129-0213-00	203.1.2304.046	lane connect board	V1.1	1
7	L129-0223-00	203.1.2304.058	Large fence board	V1.1	1
8	L129-0229-00	203.1.2304.068	Ball board	V1.1	1
9	L129-0231-00	203.1.2304.071	Drawer long strengthen board	V1.1	1
10	L129-0232-00	203.1.2304.066	Speaker L fixing board	V1.1	1
11	L129-0235-00	203.1.2304.067	Speaker R fixing board	V1.1	1
12	L129-0236-00	203.1.2304.039	Sliding L side board	V1.1	1
13	L129-0237-00	203.1.2304.040	Sliding R side board	V1.1	1
14	L129-0256-00	203.1.2304.073	R lane front base board	V1.1	1
15	L129-0259-00	203.1.2304.076	R bottom lane front board	V1.1	1
	L129-0247-00	206.1.2304.133	lane bottom foam	V1.1	1
16	L129-0260-00	203.1.2304.078	R side short board	V1.1	1
	L129-0249-00	206.1.2304.135	lane side back foam	V1.1	1
17	L129-0263-00	203.1.2304.111	Small fence board	V1.1	1
18	L129-0242-00	203.1.2304.072	Drawer short strengthen board	V1.1	1
19	L129-0230-00	203.1.2304.070	Side fence board(long)	V1.1	1
	L129-0250-00	206.1.2304.136	lane side front foam	V1.1	1

9.7 L&R Side Bottom Box

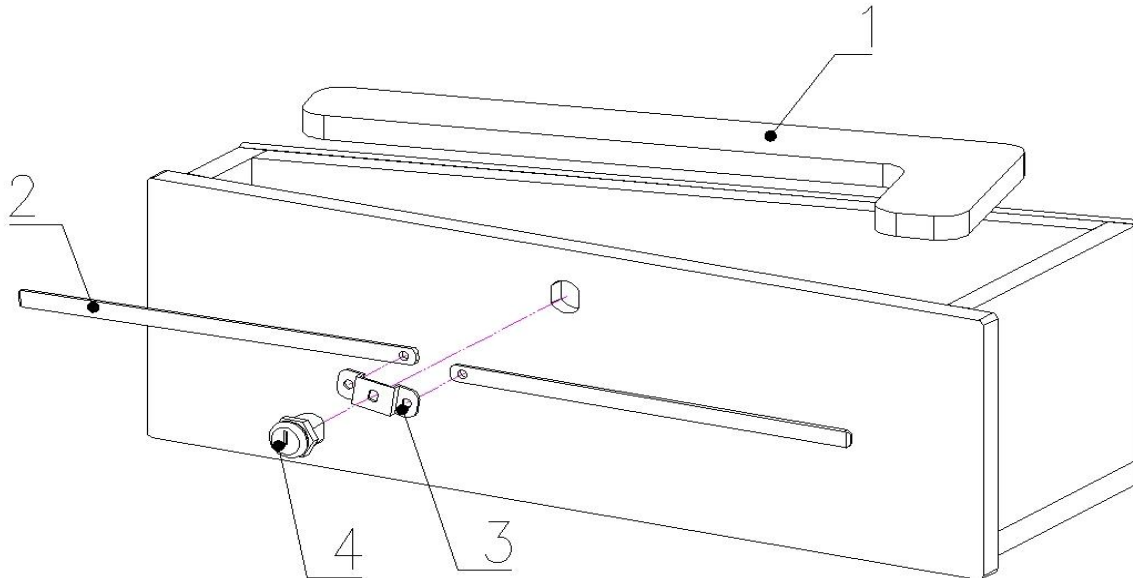

No.	Part No.	Code No.	Name	Version	Qty
1	L129-0279-00	203.1.2304.084	Cleaning hook	V1.1	1×2
2	L129-0280-00	202.1.1605D.003	Bolt	V1.1	2×2
3	L129-0281-00	202.1.1605D.004	lock pin	V1.1	1×2
4	L129-0253-00	2.53.00171001	171A lock	V1.1	1×2

9.8 L Side Bottom Box Wooden Case

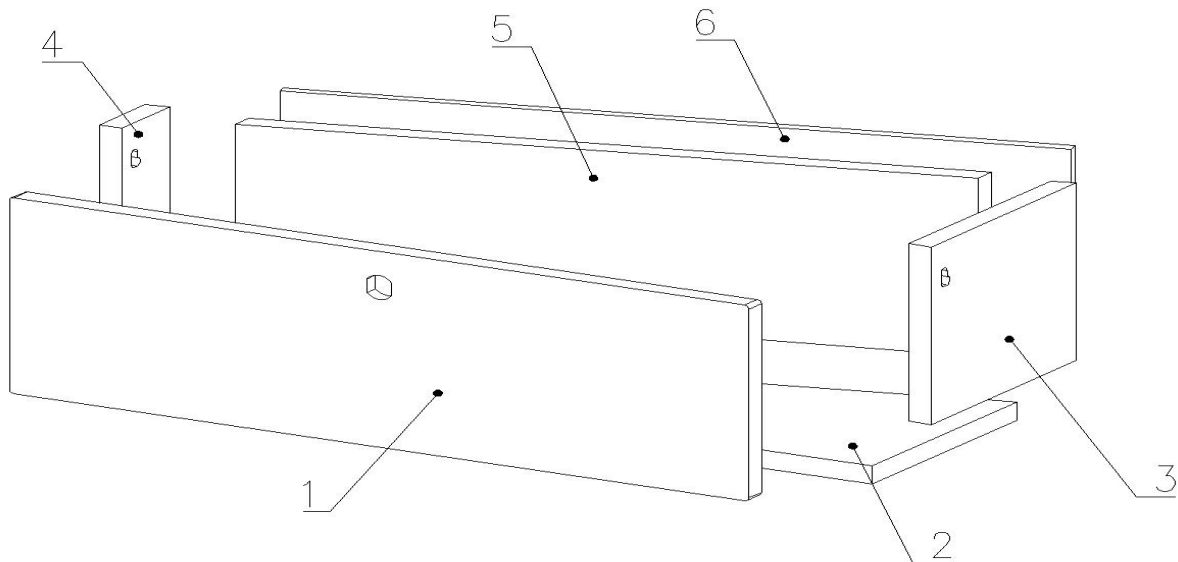

No.	Part No.	Code No.	Name	Version	Qty
1	L129-0273-00	203.1.2304.079	Drawing door board	V1.1	1
2	L129-0274-00	203.1.2304.080	Drawing base board	V1.1	1
3	L129-0275-00	203.1.2304.081	L drawing R side board	V1.1	1
4	L129-0276-00	203.1.2304.082	L drawing L side board	V1.1	1
5	L129-0277-00	203.1.2304.083	Drawing back board	V1.1	1
6	L129-0278-00	206.1.1605D.003	Drawing foam	V1.1	1

9.9 R Side Bottom Box Wooden Case

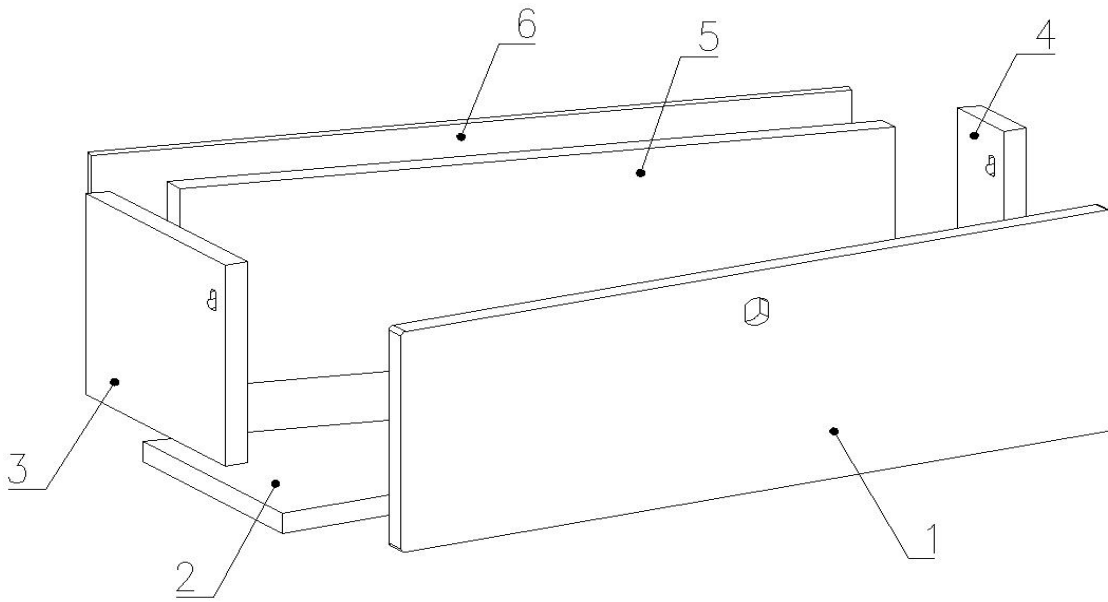

No.	Part No.	Code No.	Name	Version	Qty
1	L129-0273-00	203.1.2304.079	Drawing door board	V1.1	1
2	L129-0274-00	203.1.2304.080	Drawing base board	V1.1	1
3	L129-0284-00	203.1.2304.085	R drawing R side board	V1.1	1
4	L129-0285-00	203.1.2304.086	R drawing L side board	V1.1	1
5	L129-0277-00	203.1.2304.083	Drawing back board	V1.1	1
6	L129-0278-00	206.1.1605D.003	Drawing foam	V1.1	1

9.10 Ball-Pass Wooden Bracket

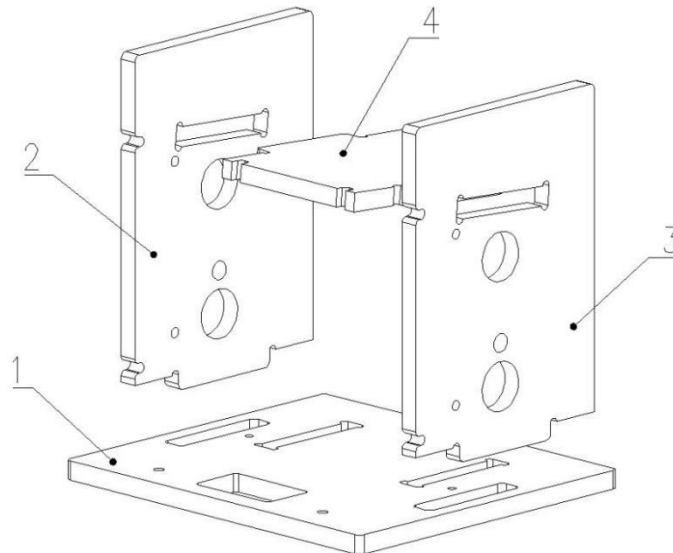

No.	Part No.	Code No.	Name	Version	Qty
1	L129-0288-00	203.1.2304.087	Ball pass base board	V1.1	1X2
2	L129-0289-00	203.1.2304.088	Ball pass L vertical board	V1.1	1X2
3	L129-0290-00	203.1.2304.089	Ball pass top board	V1.1	1X2
4	L129-0291-00	203.1.2304.090	Ball pass R vertical board	V1.1	1X2

9.11 Ball-Pass Assembly

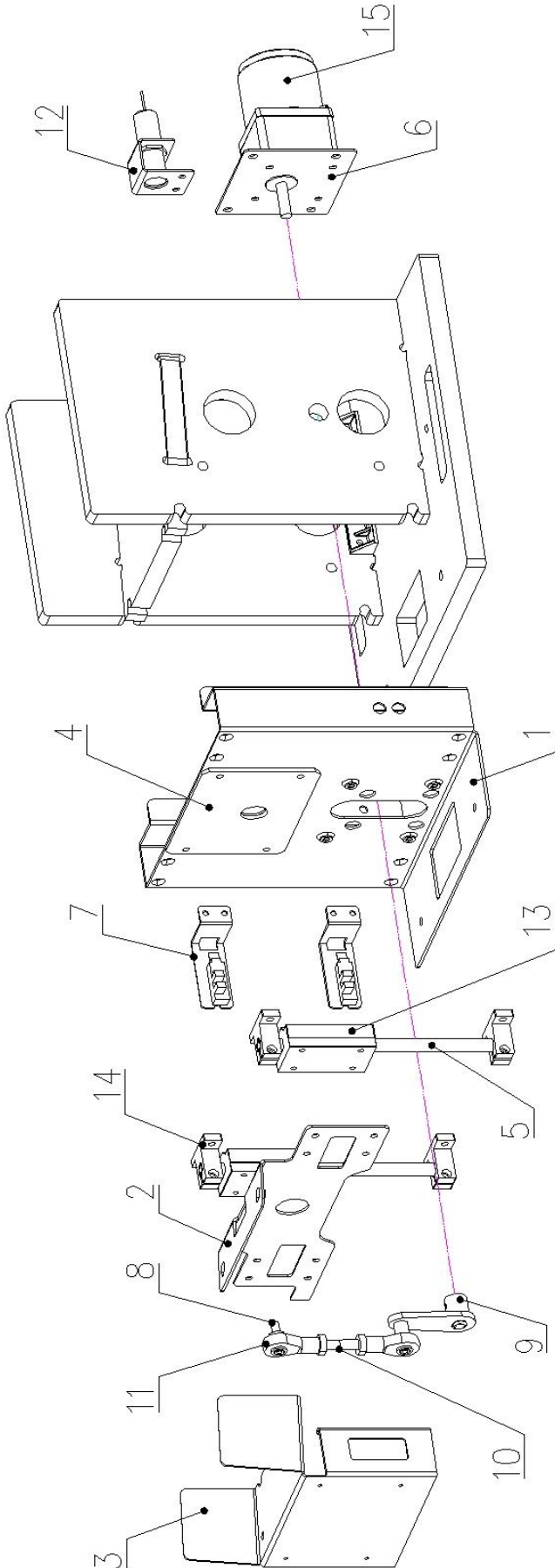

No.	Part No.	Code No.	Name	Version	Qty
1	L129-0292-00	202.1.2304.193	Mounting base plate	V1.1	1×2
2	L129-0293-00	202.1.2304.194	Sliding connect plate	V1.1	1×2
3	L129-0294-00	202.1.2304.195	Ball mounting plate	V1.1	1×2
4	L129-0295-00	206.1.2304.137	Buffer plate	V1.1	1×2
5	L129-0296-00	202.1.2304.196	Straight axle	V1.1	2×2
6	L129-0297-00	202.1.2304.197	Motor mounting plate	V1.1	1×2
7	L129-0298-00	202.1.2304.198	Mounting base sensor	V1.1	2×2
8	L129-0299-00	202.1.2304.199	Rod	V1.1	1×2
9	L129-0300-00	202.1.2304.200	Crank	V1.1	1×2
10	L129-0302-00	202.1.2304.201	Connect rod	V1.1	1×2
11	L129-0303-00	201.06.08.0305	Rod bearing	V1.1	2×2
12	L129-0304-00	202.1.1605.049	Sensor fixing plate A	V1.1	1×2
13	L129-0305-00	2.51.05.030009	Straight bearing block	V1.1	2×2
14	L129-0306-00	2.51.05.020032	Guide plate	V1.1	4×2
15	L129-0307-00	2.34.05.000051	Motor	V1.1	1×2

9.12 Coin Box

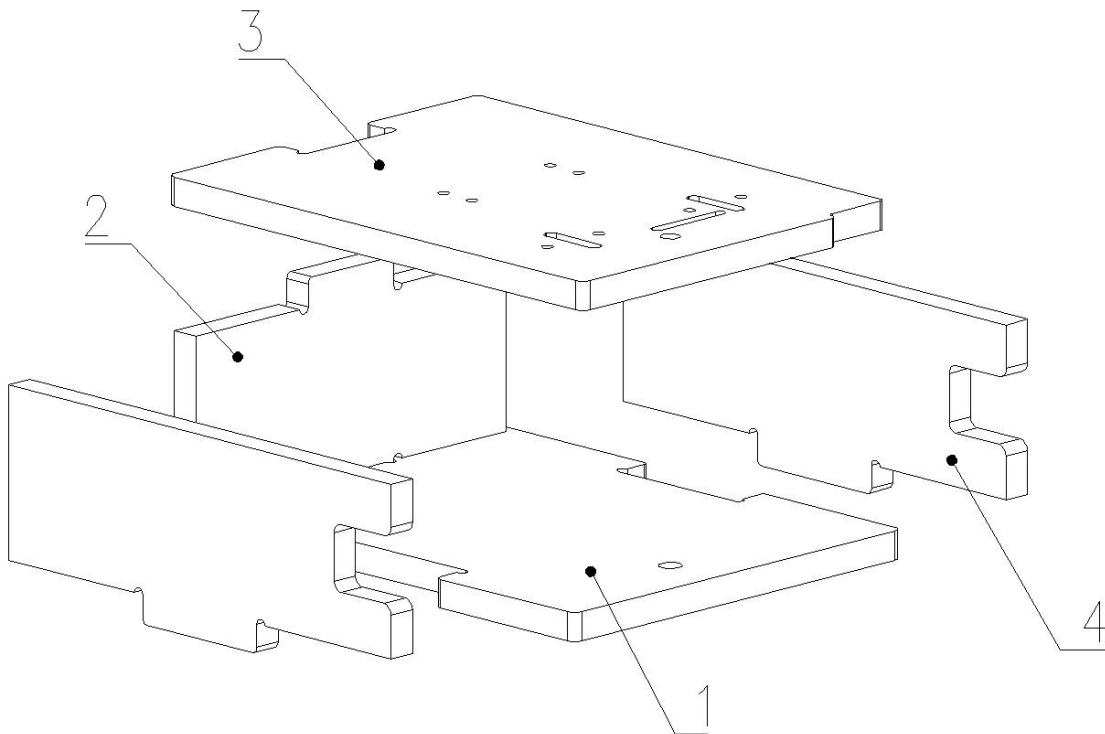

No.	Part No.	Code No.	Name	Version	Qty
1	L129-0309-00	203.1.2304.091	Coin box base board	V1.1	1
2	L129-0310-00	203.1.2304.092	Coin box back board	V1.1	1
3	L129-0311-00	203.1.2304.093	Coin box top board	V1.1	1
4	L129-0312-00	203.1.2304.094	Coin box side board	V1.1	2

9.13 Lane Assembly

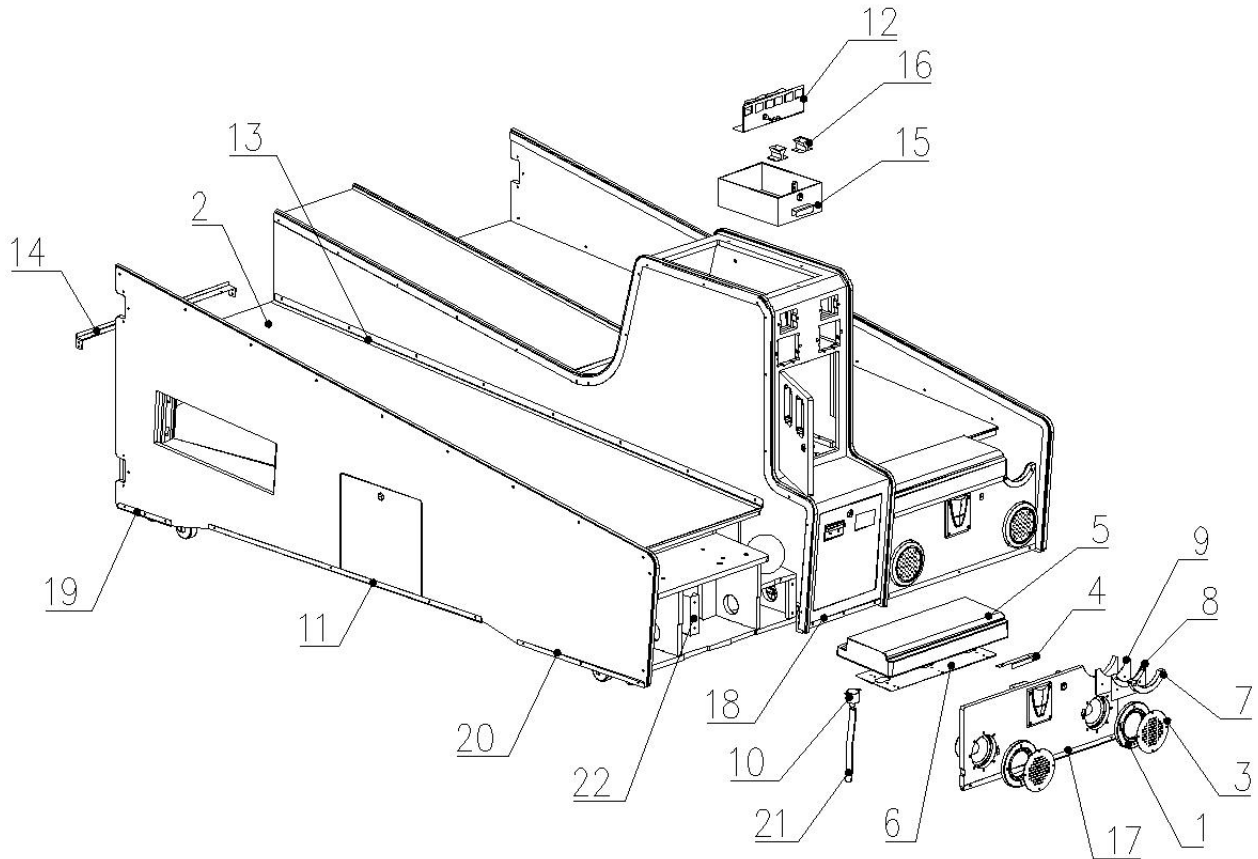

No.	Part No.	Code No.	Name	Version	Qty
1	L129-0313-00	206.1.2304.139	Speaker light plastic	V1.1	4
2	L129-0314-00	206.1.2304.140	Lane Glass	V1.1	2
3	L129-0316-00	202.1.2304.202	Speaker cover	V1.1	4
4	L129-0317-00	202.1.2304.203	Speaker position plate	V1.1	2
5	L129-0319-00	206.1.2304.141	Ball light cover PE	V1.1	2
6	L129-0320-00	206.1.2304.142	Ball light PVC	V1.1	2
7	L129-0322-00	206.1.2304.143	Ball exit plastic	V1.1	2
8	L129-0323-00	202.1.2304.204	Ball arc plate	V1.1	2
9	L129-0324-00	206.1.2304.144	Ball buffer	V1.1	2
10	L129-0355-00	202.1.2304.217	Pipe plate	V1.1	2
11	L129-0356-00	202.1.2304.218	Lane L corner plate	V1.1	1
	L129-0357-00	202.1.2304.219	Lane R corner plate	V1.1	1
12	L129-0358-00	202.1.2304.220	Counter bracket	V1.1	1
13	L129-0359-00	202.1.2304.221	Lane pressing plate	V1.1	4
14	L129-0133-00	202.1.2304.176	lane strengthen plate	V1.1	2
15	L129-0360-00	202.1.1605.027A	Coin box	V1.1	1
16	L129-0361-00	202.1.1605.028	Coin-in tube plate	V1.1	2
17	L129-0362-00	202.1.1605.032	Angle guard plate	V1.1	2
18	L129-0363-00	202.1.1605.033	Angle guard plate	V1.1	1
19	L129-0364-00	202.1.1605.069	Angle guard plate	V1.1	2
20	L129-0365-00	202.1.1605.070	Angle guard plate	V1.1	2
21	L129-0366-00	206.1.1605.042	Pipe	V1.1	2
	L129-0367-00	2.51.03.000005	Stainless steel throat hoop	V1.1	2
22	L129-0368-00	2.60.00075000	Ticket box	V1.1	2

9.14 Lane Middle L Light Plastic

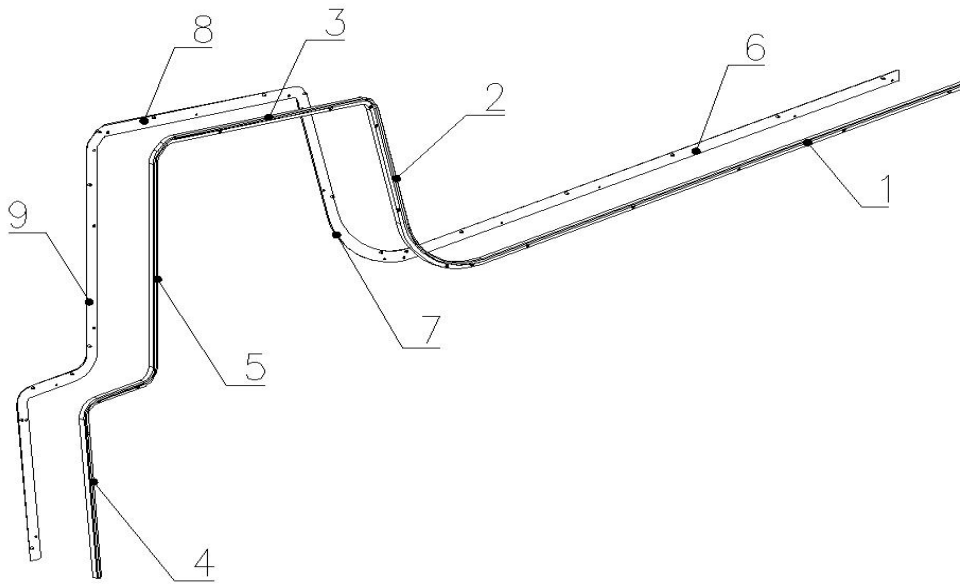

No.	Part No.	Code No.	Name	Version	Qty
1	L129-0326-00	206.1.2304.145	L side light plastic 1	V1.1	1
2	L129-0327-00	206.1.2304.146	L side light plastic 2	V1.1	1
3	L129-0328-00	206.1.2304.147	L side light plastic 3	V1.1	1
4	L129-0329-00	206.1.2304.148	L side light plastic 4	V1.1	1
5	L129-0330-00	206.1.2304.149	L side light plastic 5	V1.1	1
6	L129-0331-00	202.1.2304.205	L side light mounting plate 1	V1.1	1
7	L129-0332-00	202.1.2304.206	L side light mounting plate 2	V1.1	1
8	L129-0333-00	202.1.2304.207	L side light mounting plate 3	V1.1	1
9	L129-0334-00	202.1.2304.208	L side light mounting plate 4	V1.1	1

9.15 Lane L Light Plastic

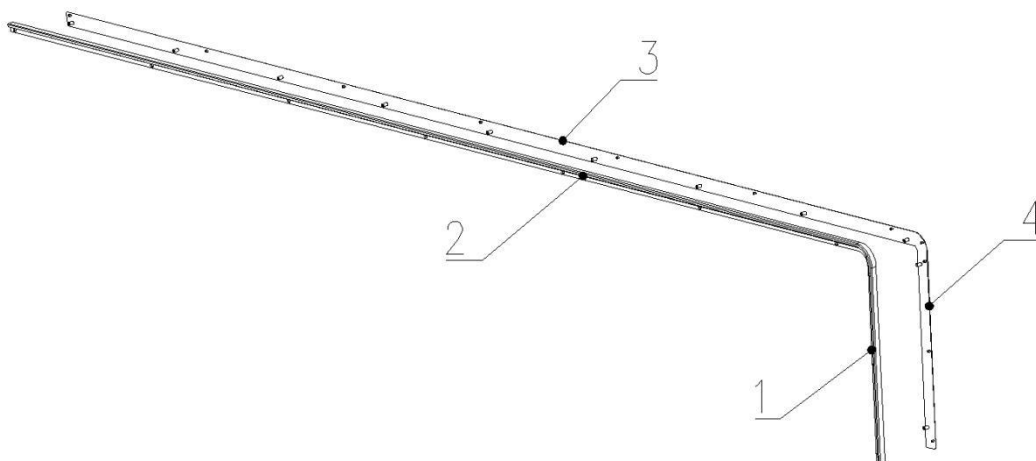

No.	Part No.	Code No.	Name	Version	Qty
1	L129-0346-00	206.1.2304.155	L side light plastic(short)	V1.1	1
2	L129-0347-00	206.1.2304.156	L side light plastic(long)	V1.1	1
3	L129-0348-00	202.1.2304.213	L side light mounting plate(long)	V1.1	1
4	L129-0349-00	202.1.2304.214	L side light mounting plate(short)	V1.1	1

9.16 Lane Middle R Light Plastic

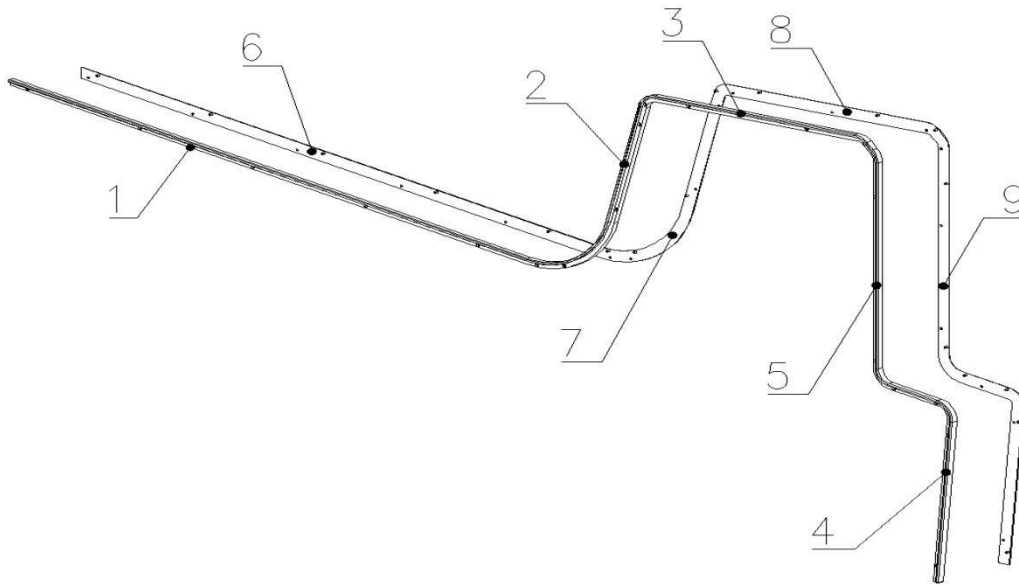

No.	Part No.	Code No.	Name	Version	Qty
1	L129-0336-00	206.1.2304.150	R side light plastic 1	V1.1	1
2	L129-0337-00	206.1.2304.151	R side light plastic 2	V1.1	1
3	L129-0338-00	206.1.2304.152	R side light plastic 3	V1.1	1
4	L129-0339-00	206.1.2304.153	R side light plastic 4	V1.1	1
5	L129-0340-00	206.1.2304.154	R side light plastic 5	V1.1	1
6	L129-0341-00	202.1.2304.209	R side light mounting plate 1	V1.1	1
7	L129-0342-00	202.1.2304.210	R side light mounting plate 2	V1.1	1
8	L129-0343-00	202.1.2304.211	R side light mounting plate 3	V1.1	1
9	L129-0344-00	202.1.2304.212	R side light mounting plate 4	V1.1	1

9.17 Lane R Light Plastic

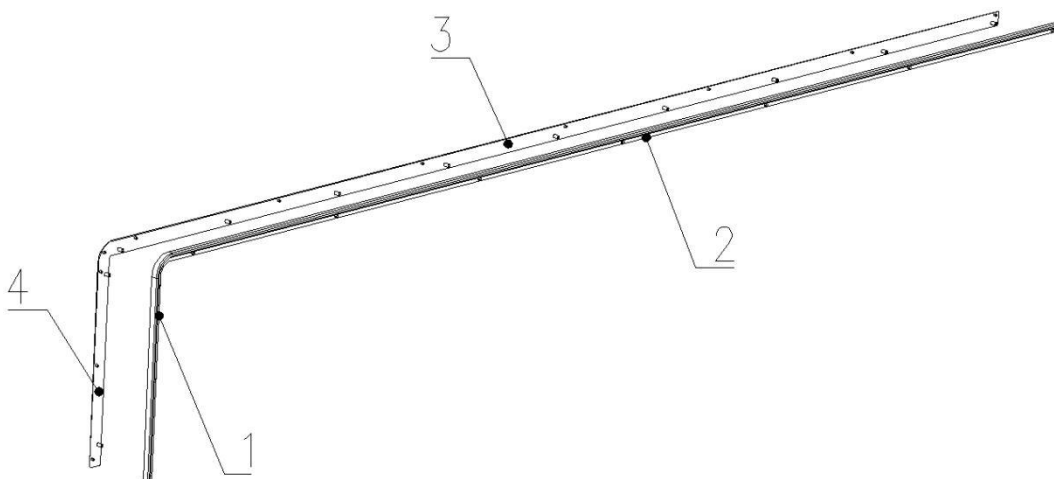

No.	Part No.	Code No.	Name	Version	Qty
1	L129-0351-00	206.1.2304.157	R side light plastic(short)	V1.1	1
2	L129-0352-00	206.1.2304.158	R side light plastic(long)	V1.1	1
3	L129-0353-00	202.1.2304.215	R side light mounting plate(long)	V1.1	1
4	L129-0354-00	202.1.2304.216	R side light mounting plate(short)	V1.1	1

9.18 Front Marquee Assembly

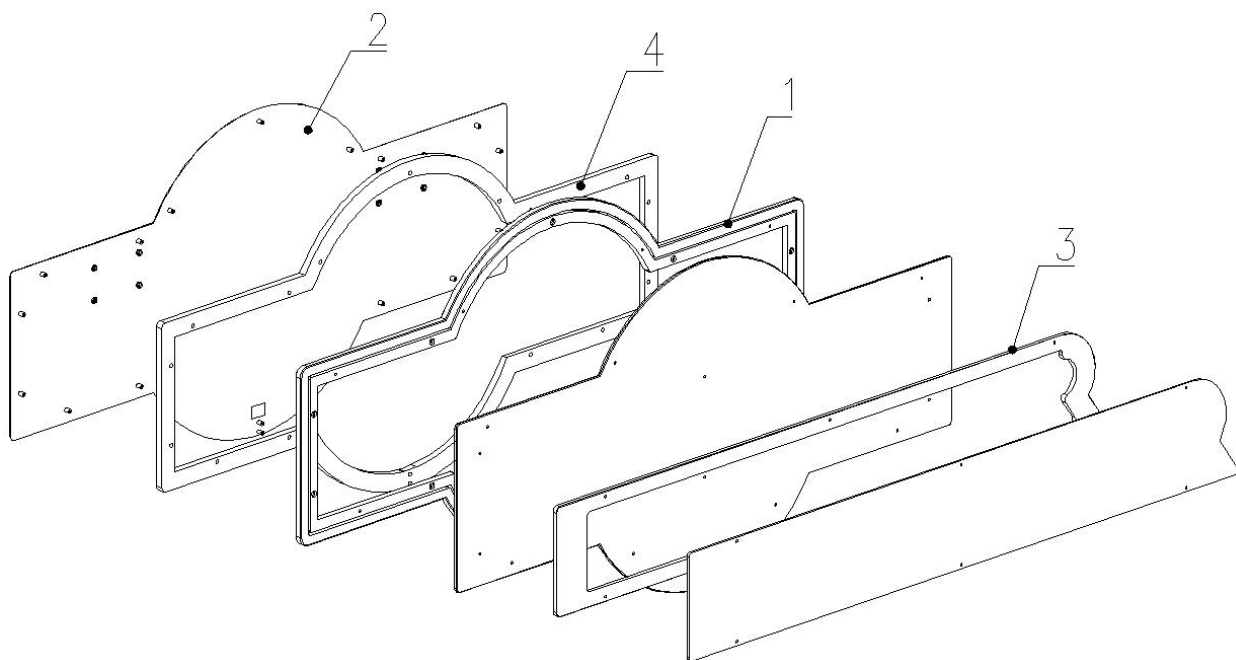

No.	Part No.	Code No.	Name	Version	Qty
1	L129-0402-00	206.1.2304.159	Marquee L upper light plastic	V1.1	1
	L129-0403-00	206.1.2304.160	Marquee L bottom light plastic	V1.1	1
	L129-0404-00	206.1.2304.161	Marquee R upper light plastic	V1.1	1
	L129-0405-00	206.1.2304.162	Marquee R bottom light plastic	V1.1	1
	L129-0406-00	206.1.2304.163	Marquee upper light plastic	V1.1	1
	L129-0407-00	206.1.2304.164	Marquee bottom light plastic	V1.1	1
2	L129-0408-00	202.1.2304.222	Marquee back plate	V1.1	1
3	L129-0409-00	206.1.2304.165	Front marquee upper light plastic	V1.1	1
	L129-0410-00	206.1.2304.166	Front marquee bottom light plastic	V1.1	1
4	L129-0411-00	203.1.2304.095	Large marquee support board	V1.1	1

9.19 Marquee Assembly

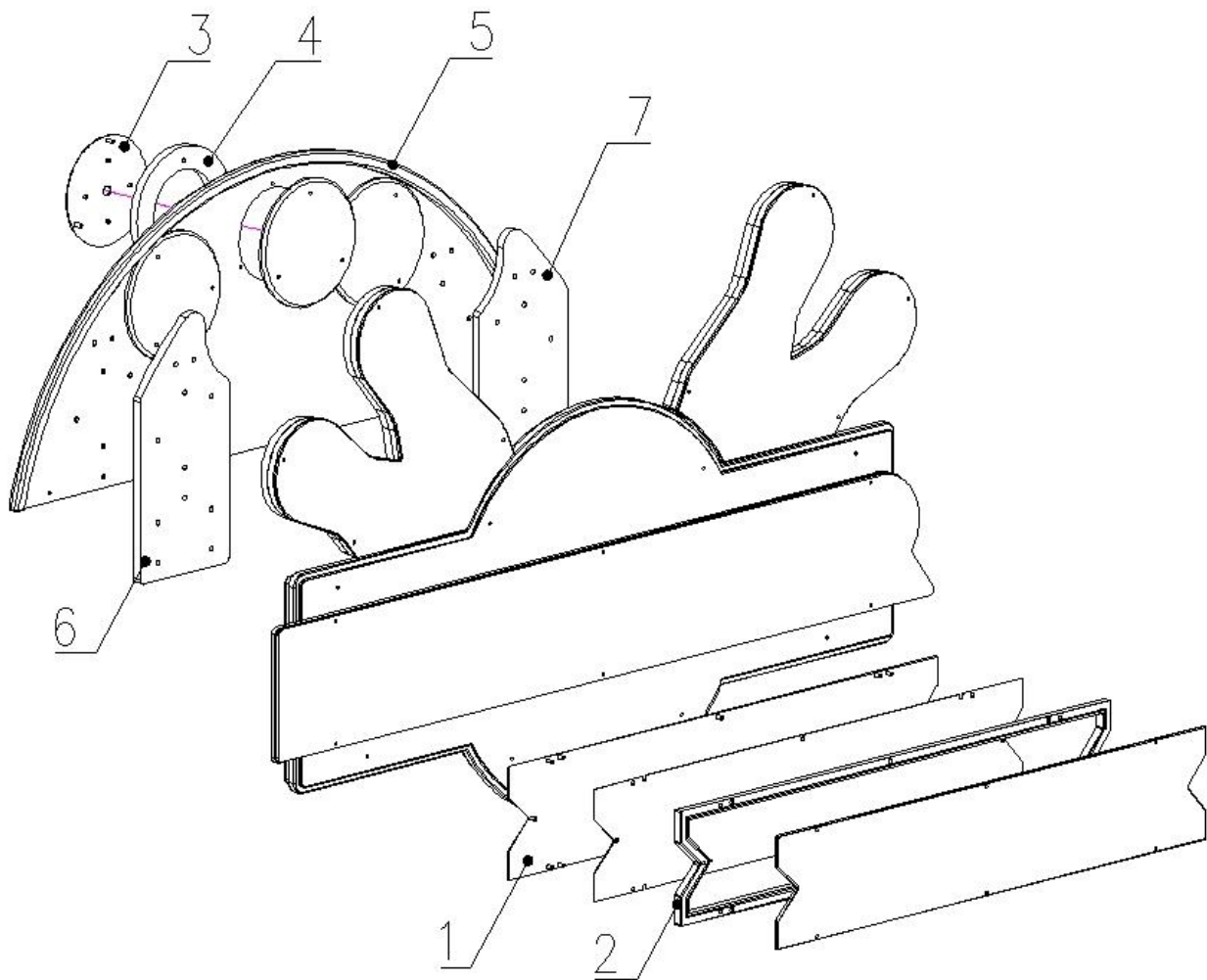

No.	Part No.	Code No.	Name	Version	Qty
1	L129-0416-00	202.1.2304.223	Small marquee base plate	V1.1	1
2	L129-0417-00	206.1.2304.167	Small marquee light plastic	V1.1	1
3	L129-0425-00	202.1.2304.224	Round light back plate	V1.1	3
4	L129-0426-00	203.1.2304.099	Round base board	V1.1	3
5	L129-0427-00	206.1.2304.168	Large light plastic	V1.1	1
6	L129-0428-00	203.1.2304.100	Front&back connect board L	V1.1	1
7	L129-0429-00	203.1.2304.101	Front&back connect board R	V1.1	1

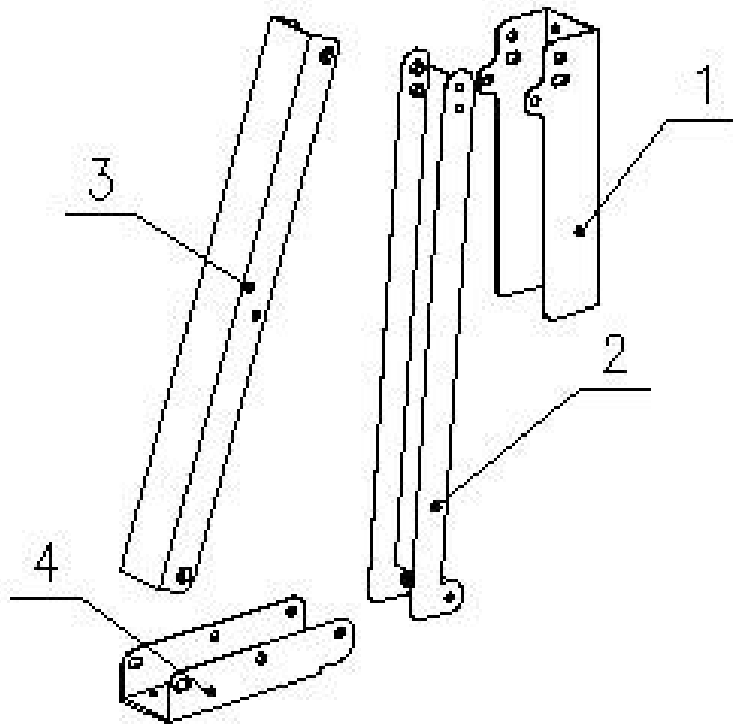

No.	Part No.	Code No.	Name	Version	Qty
1	L129-0430-00	202.1.2304.225	Marquee fixing plate	V1.1	1×2
2	L129-0431-00	202.1.2304.226	Marquee rod	V1.1	1×2
3	L129-0437-00	202.1.1605.037	Fixed rod plate	V1.1	1×2
4	L129-0436-00	202.1.1605.036	Marquee fixing bracket	V1.1	1×2

9.20 Rotating Shaft

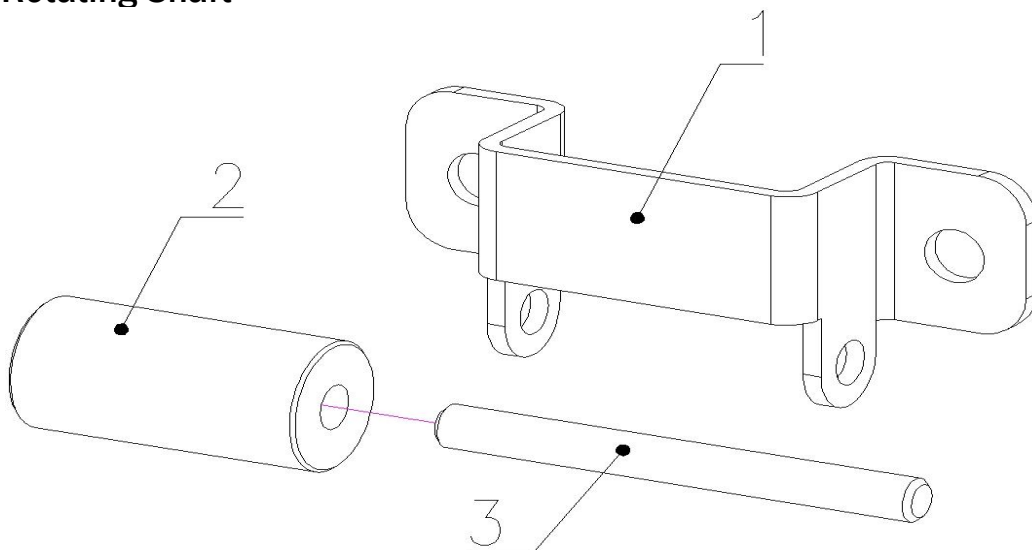

No.	Part No.	Code No.	Name	Version	Qty
1	L129-0509-00	202.1.2304.232	Rolling wheel fixing plate	V1.1	1×2
2	L129-0510-00	206.1.2304.171	Rotation axle POM	V1.1	1×2
3	L129-0511-00	202.1.2304.233	Small axle	V1.1	1×2

9.21 L Ball Pin Marquee

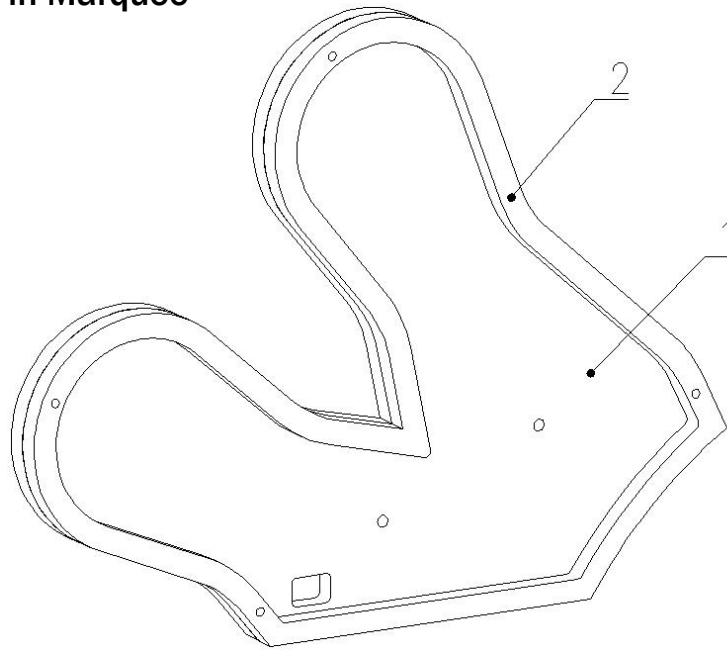

No.	Part No.	Code No.	Name	Version	Qty
1	L129-0421-00	203.1.2304.096	L ball pin base board	V1.1	1
2	L129-0422-00	203.1.2304.097	Ball pin pad board	V1.1	1

9.22 R Ball Pin Marque

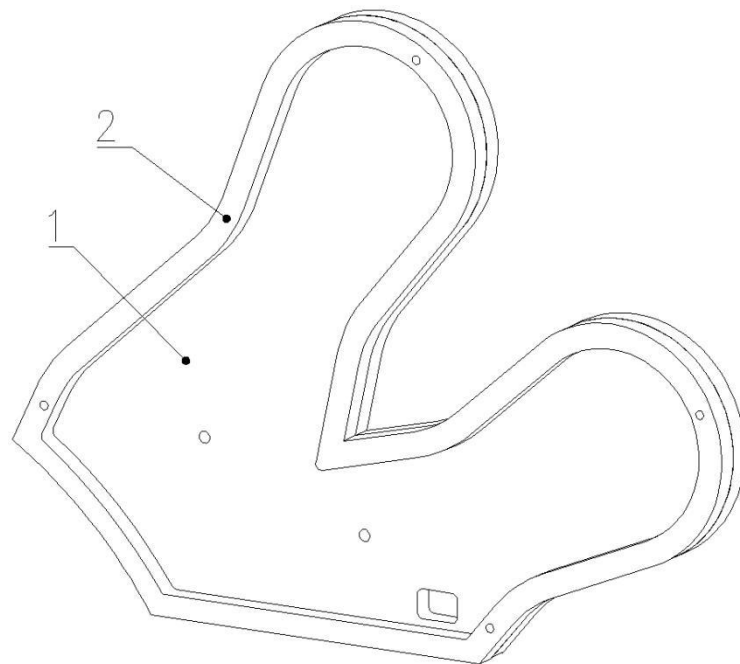

No.	Part No.	Code No.	Name	Version	Qty
1	L129-0424-00	203.1.2304.098	R ball pin base board	V1.1	1
2	L129-0422-00	203.1.2304.097	Ball pin pad board	V1.1	1

9.23 Hopper Assembly

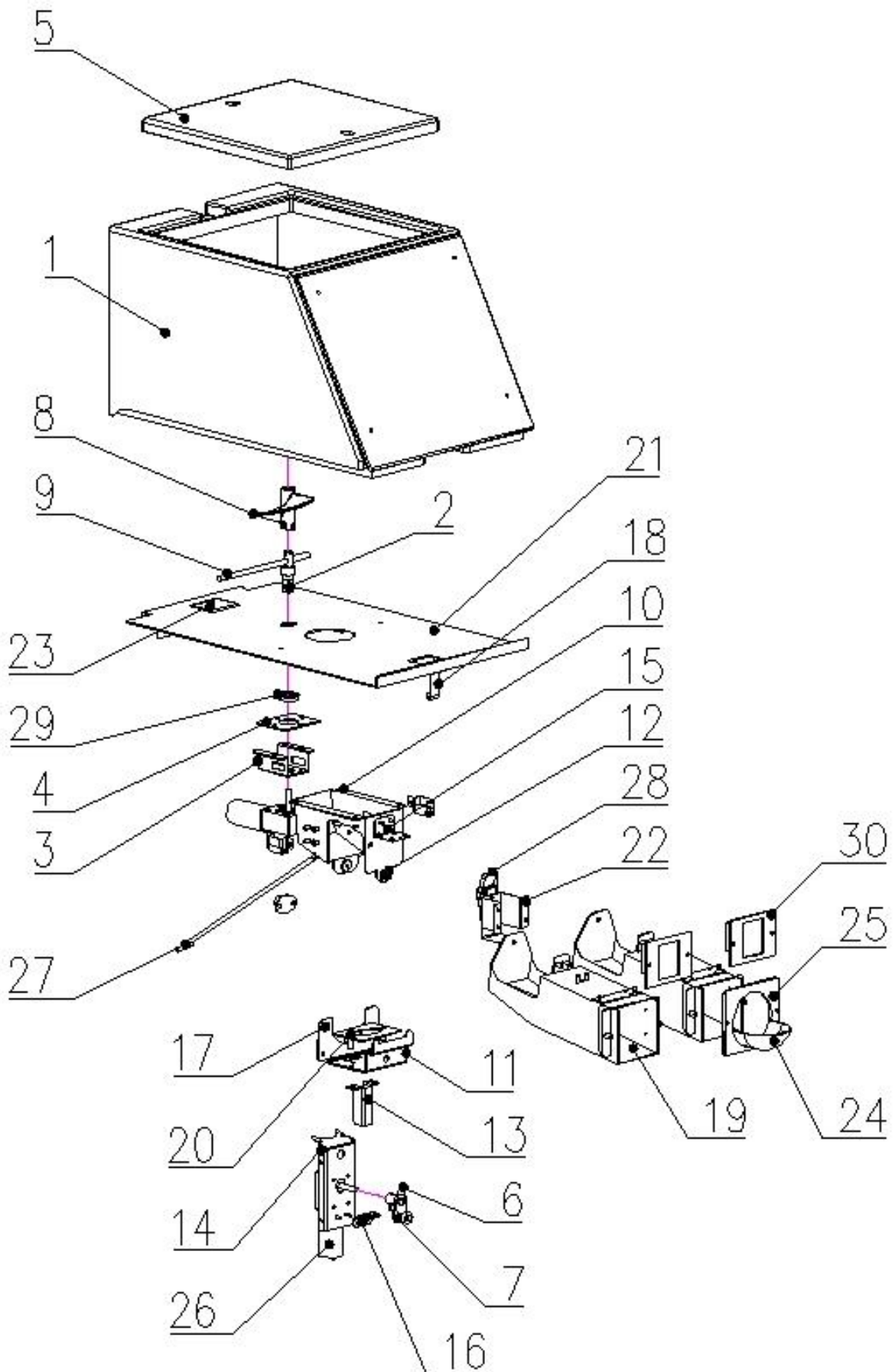

No.	Part No.	Code No.	Name	Version	Qty
1	L129-0501-00	206.1.2304.169	Hopper box	V1.1	1
2	L129-0502-00	202.1.2304.227	Swing rod plate	V1.1	1
3	L129-0503-00	202.1.2304.228	Motor bracket	V1.1	1
4	L129-0504-00	202.1.2304.229	Motor bracket pad plate	V1.1	1
5	L129-0505-00	206.1.2304.170	Hopper cover	V1.1	1
6	L129-0506-00	202.1.2304.230	Sensor plate	V1.1	1
7	L129-0507-00	202.1.2304.231	L&R crank	V1.2	1
	L129-0524-00	206.1.2304.175	Swing wheel POM	V1.1	1
8	L129-0512-00	206.1.2304.172	Up-ball POM	V1.1	1
9	L129-0513-00	206.1.2304.173	Power ball stiring PU	V1.1	1
10	L129-0514-00	202.1.2304.234	Saving plate	V1.1	1
11	L129-0515-00	202.1.2304.235	Power ball out plate	V1.1	1
12	L129-0516-00	202.1.2304.236	Power ball Cu plate	V1.1	2
13	L129-0517-00	202.1.2304.237	Power ball transmission plate	V1.1	1
14	L129-0518-00	202.1.2304.238	Power ball motor moving plate	V1.1	1
15	L129-0519-00	202.1.2304.239	Power ball sensor mounting plate	V1.1	1
16	L129-0520-00	202.1.2304.240	Small sensor mounting plate	V1.1	1
17	L129-0521-00	206.1.2304.174	Blocking PVC	V1.1	1
18	L129-0522-00	202.1.2304.241	Bending hook	V1.1	1
19	L129-0523-00	202.1.2304.242	Power ball plate	V1.1	2
20	L129-0525-00	202.1.2304.243	Power ball pad plate	V1.2	1
21	L129-0526-00	202.1.2304.244	Power ball base plate	V1.1	1
22	L129-0527-00	202.1.2304.245	Plate	V1.1	1
23	L129-0528-00	202.1.2304.246	Hopper rotating plate	V1.1	1
24	L129-0529-00	202.1.2304.247	Hopper exit frame	V1.1	2
25	L129-0530-00	206.1.2304.177	Hopper exit	V1.2	2
26	L129-0533-00	2.34.04.000265	DC motor	V1.1	2
27	L129-0534-00	2.59.00025036	Stainless steel hook	V1.1	1
28	L129-0535-00	2.51.02.000001	Door buckle	V1.1	1
29	L129-0536-00	201.06.000334	Bearing	V1.1	1
30	L129-0537-00	202.1.2304.248	Scanner mounting plate	V1.1	2

9.24 Decals

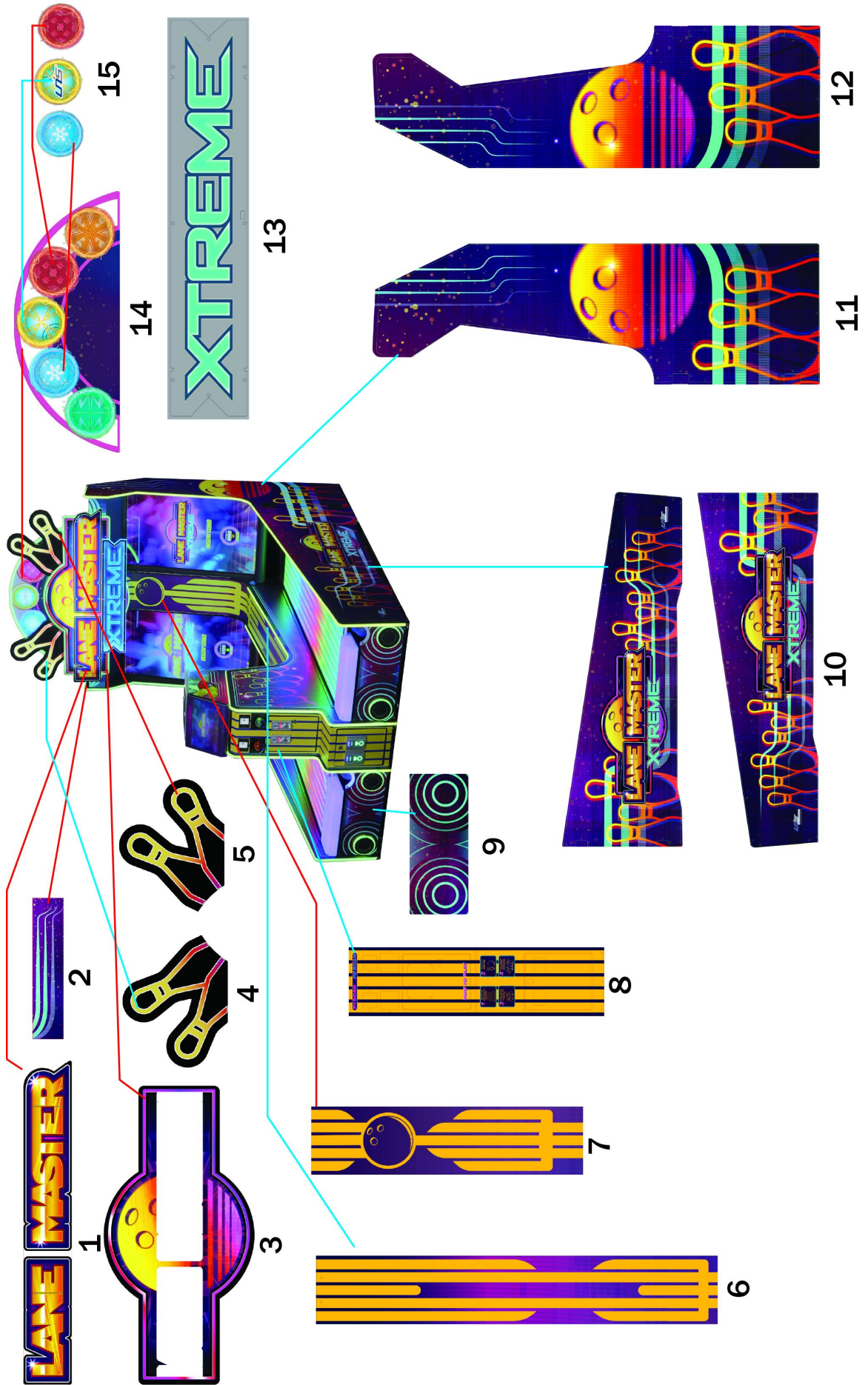

No.	Part No.	Code No.	Name	Version	Qty
1	L129-0413-00	205.1.2304.013	Small marquee plastic	V1.1	1
2	L129-0702-00	205.1.2304.002	Front upper decal L	V1.1	1
3	L129-0412-00	205.1.2304.012	Marquee plastic	V1.1	1
4	L129-0432-00	205.1.2304.016	L ball pin plastic	V1.1	1
5	L129-0433-00	205.1.2304.017	R ball pin plastic	V1.1	1
6	L129-0711-00	205.1.2304.011	Lane back decal	V1.1	1
7	L129-0703-00	205.1.2304.003	Monitor decal	V1.1	1
8	L129-0706-00	205.1.2304.006	Coin board decal	V1.1	1
9	L129-0705-00	205.1.2304.005	Speaker fixing board PVC	V1.1	1
10	L129-0704-00	205.1.2304.004	Front L side board decal	V1.1	1
	L129-0710-00	205.1.2304.010	Front R side board decal	V1.1	1
11	L129-0709-00	205.1.2304.009	Monitor R side decal	V1.1	1
12	L129-0701-00	205.1.2304.001	Monitor L side decal	V1.1	1
13	L129-0419-00	205.1.2304.018	Xtreme plastic	V1.1	1
14	L129-0435-00	205.1.2304.015	Back POP andy board	V1.1	1
15	L129-0434-00	205.1.2304.014	Round plastic	V1.1	1

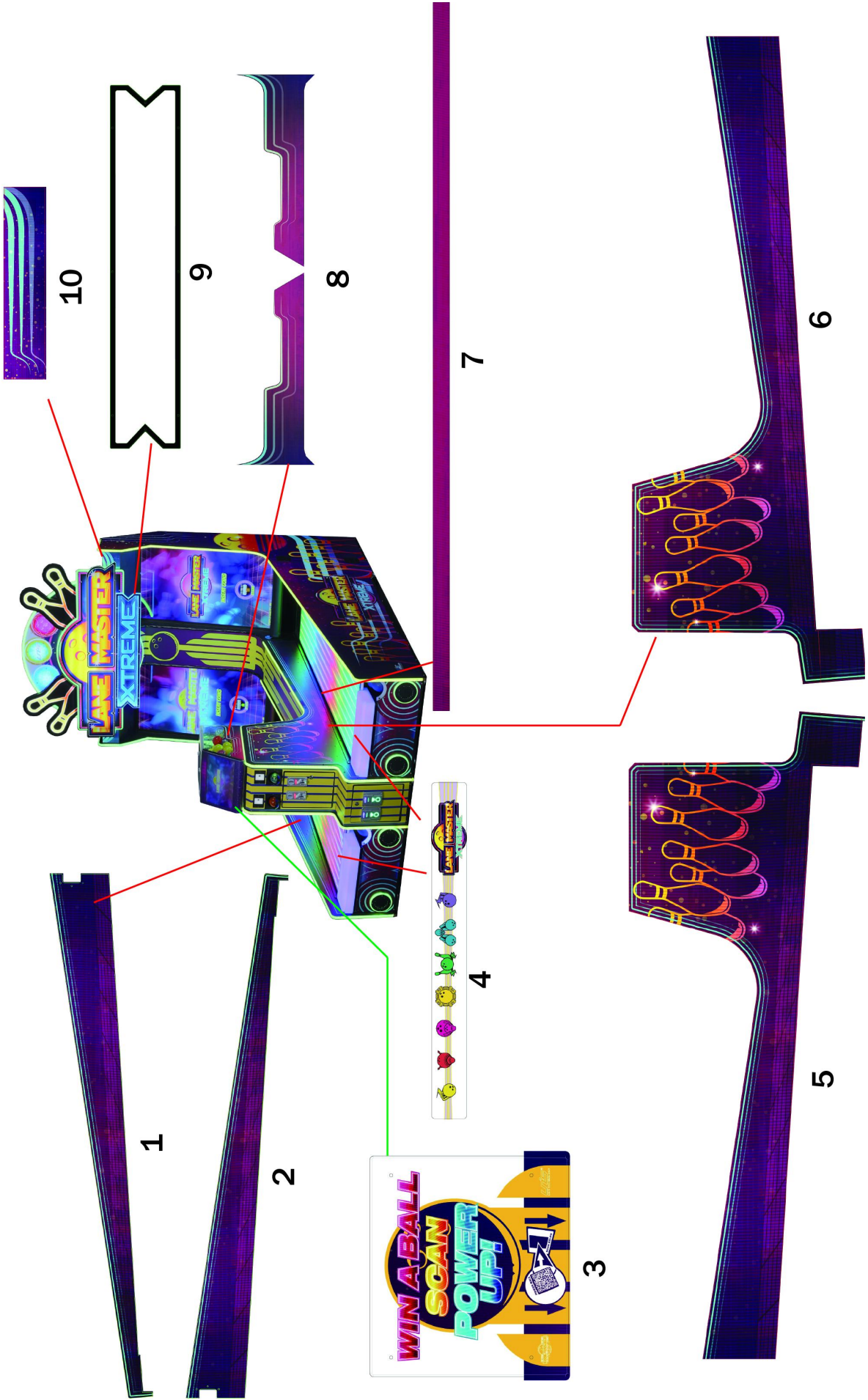

No.	Part No.	Code No.	Name	Version	Qty
1	L129-0708-00	205.1.2304.008	L lane inner decal	V1.1	1
2	L129-0713-00	205.1.2304.020	R lane inner decal	V1.1	1
3	L129-0531-00	205.1.2304.028	Hopper shading plastic	V1.1	1
4	L129-0315-00	205.1.2304.029	Lane front shading decal	V1.1	1
5	L129-0707-00	205.1.2304.007	L mid lane decal	V1.1	1
6	L129-0712-00	205.1.2304.019	R mid lane decal	V1.1	1
7	L129-0717-00	205.1.2304.026	Lane side decal	V1.1	1
8	L129-0715-00	205.1.2304.024	L hopper decal	V1.1	1
	L129-0716-00	205.1.2304.025	R hopper decal	V1.1	1
9	L129-0418-00	205.1.2304.022	Reflective plastic 1	V1.1	1
10	L129-0714-00	205.1.2304.021	Front upper decal R	V1.1	1

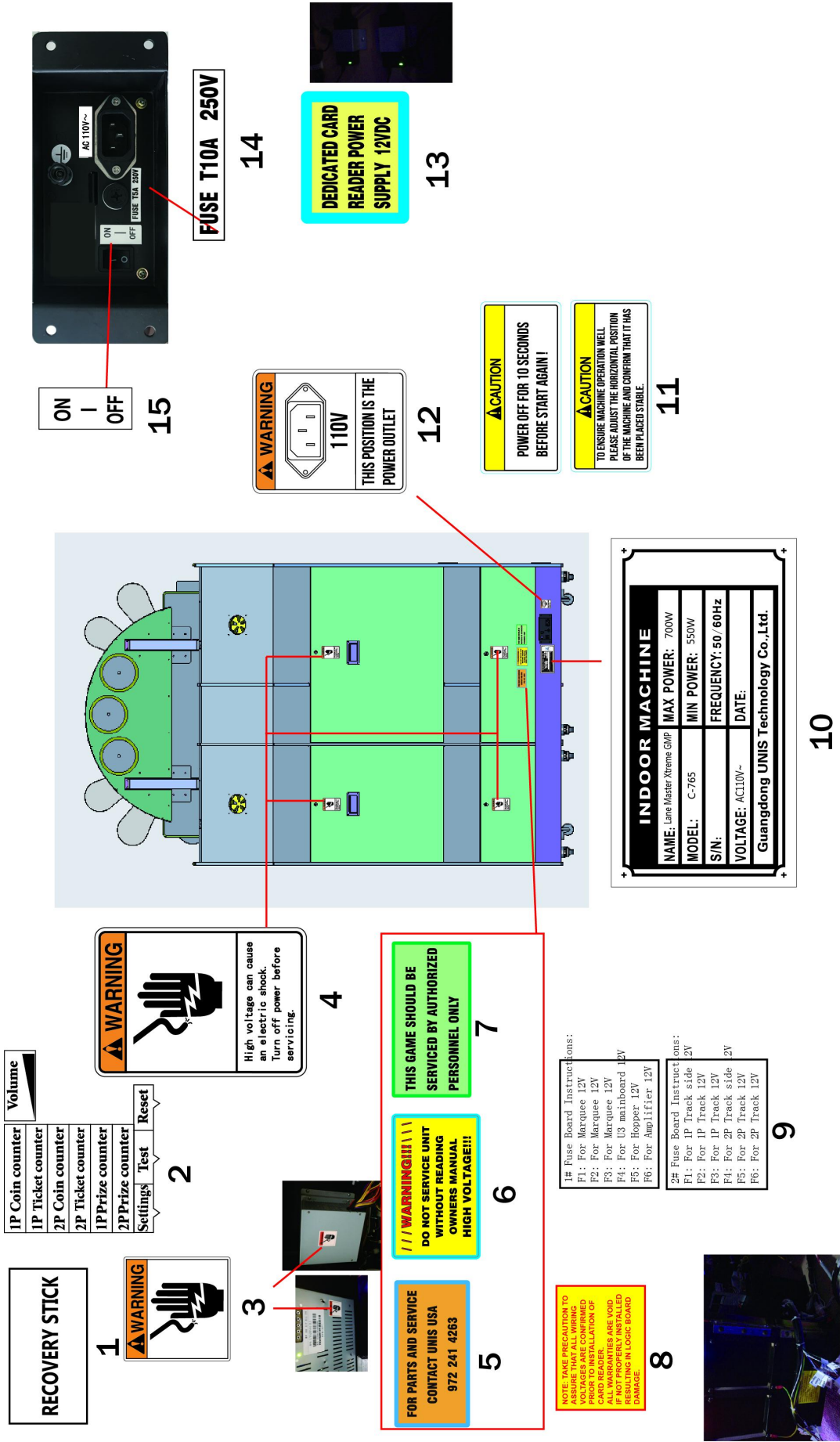

No.	Part No.	Code No.	Name	Version	Qty
1	L129-0738-00	2.56.00.000116	Recovery stick decal	V1.1	1
2	L129-0721-00	205.1.2304.033	Counter decal	V1.1	1
3	L129-0724-00	2.56.00.000036	High voltage label(s)	V1.1	4
4	L129-0730-00	2.56.00.000037	High voltage label(l)	V1.1	2
5	L129-0728-00	2.56.00.000095A	Maintenance label(l)	V1.1	1
6	L129-0726-00	2.56.00.000067A	Service label	V1.1	1
7	L129-0725-00	2.56.00.000042A	Service label 1	V1.1	1
8	L129-0731-00	205.1.1707K.020	AAMA warning decal	V1.1	1
9	L129-0720-00	205.1.2304.032	Fuse board decal	V1.1	1
10	L129-0722-00	205.1.2304.301	110V nameplate	V1.1	1
11	L129-0735-00	2.56.00.000127	Power decal	V1.1	1
12	L129-0734-00	2.56.00.000125A	110V decal	V1.1	1
13	L129-0732-00	205.1.1605A.040	Adapter decal	V1.1	1
14	L129-0727-00	2.56.00.000077	Fuse label	V1.1	1
15	L129-0723-00	2.56.00.000017	Power sw	V1.1	1

9.25 Electrical Components

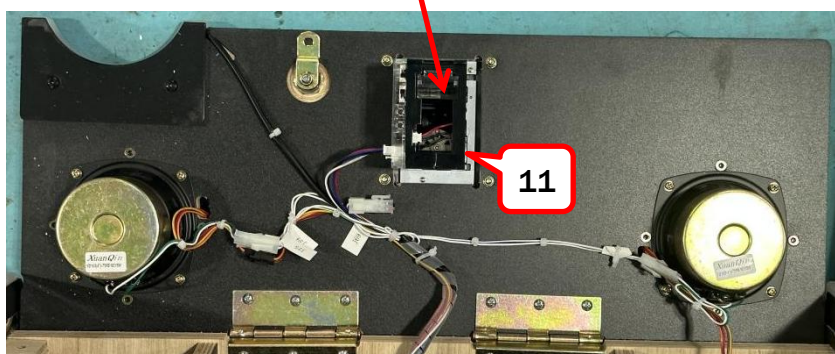

No.	Part No.	Code No.	Name	Version	Qty
1	L129-0614-00	2.12.01049005	49" monitor	V1.1	1
	L129-0605-00	2.33.07.010012	HDMI-DVI cable	V1.1	1
2	L129-0614-00	2.12.01049005	49" monitor	V1.1	1
	L129-0604-00	2.33.07.000015A	DVI cable	V1.1	1
3	L129-0631-00	2.20.02.020007	Flexible light strip	V1.1	64.96 in (1650mm)
4	L129-0631-00	2.20.02.020007	Flexible light strip	V1.1	64.96 in (1650mm)
5	L129-0631-00	2.20.02.020007	Flexible light strip	V1.1	104.33 in (2650mm)
6	L129-0631-00	2.20.02.020007	Flexible light strip	V1.1	125.98 in (3200mm)
7	L129-0631-00	2.20.02.020007	Flexible light strip	V1.1	104.33 in (2650mm)
8	L129-0631-00	2.20.02.020007	Flexible light strip	V1.1	135.82 in (3450mm)
9	L129-0631-00	2.20.02.020007	Flexible light strip	V1.1	9.84 in×4 (250mm×4)
	L129-0642-00	2.28.01.000047	Round speaker	V1.1	4
10	L129-0647-00	2.23.06000022	Coin mechanism	V1.1	2
11	L129-0648-00	2.31.00000015	Ticket dispenser	V1.1	2
12	L129-0635-00	2.20.02.020092	2811 light strip	V1.1	76.77 in ×10 (1950mm×10)
13	L129-0635-00	2.20.02.020092	2811 light strip	V1.1	76.77 in ×10 (1950mm×10)
14	L129-0649-00	2.20.02.020062	2835 blue light strip	V1.1	53.14 in (1350mm)
15	L129-0649-00	2.20.02.020062	2835 blue light strip	V1.1	5.90 in (150mm)
16	L129-0634-00	2.20.02.015019	BG5050W light strip	V1.1	66.92 in (1700mm)
17	L129-0637-00	297.6.2303001	LED light board	V1.1	3
18	L129-0631-00	2.20.02.020007	Flexible light strip	V1.1	62.99 in (1600mm)
19	L129-0632-00	2.28.06.010015	Speaker	V1.1	2
20	L129-0631-00	2.20.02.020007	Flexible light strip	V1.1	135.82 in (3450mm)
21	L129-0635-00	2.20.02.020092	2811 light strip	V1.1	88.58 in (2250mm)
	L129-0636-00	2.21.1.000040	Light controller	V1.1	1
22	L129-0634-00	2.20.02.015019	BG5050W light strip	V1.1	214.56 in (5450mm)
23	L129-0660-00	2.23.06000016	Scanner	V1.1	2

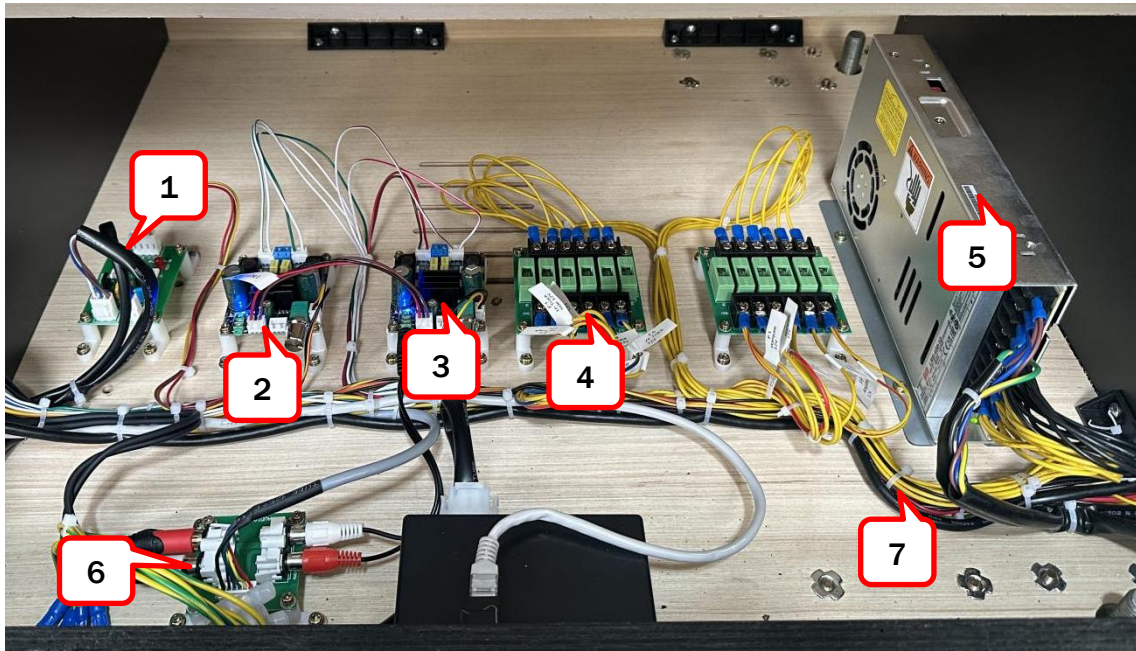

No.	Part No.	Code No.	Name	Version	Qty
1	L129-0625-00	297.1.1901002	Drive board	V1.1	1
2	L129-0624-00	2.28.03.010011	Amplifier	V1.1	1
3	L129-0624-00	2.28.03.010011	Amplifier	V1.1	1
4	L129-0612-00	2.17.14.000243A	Fuse board	V1.1	2
5	L129-0609-00	2.16.02.000171	Power supply	V1.1	1
6	L129-0629-00	2.17.02.000022	Audio adjust board	V1.1	1
	L129-0676-00	2.33.05.000022	audio cable	V1.1	1
7	L129-0601-00	2.33.09.000493	Cable set	V1.1	1

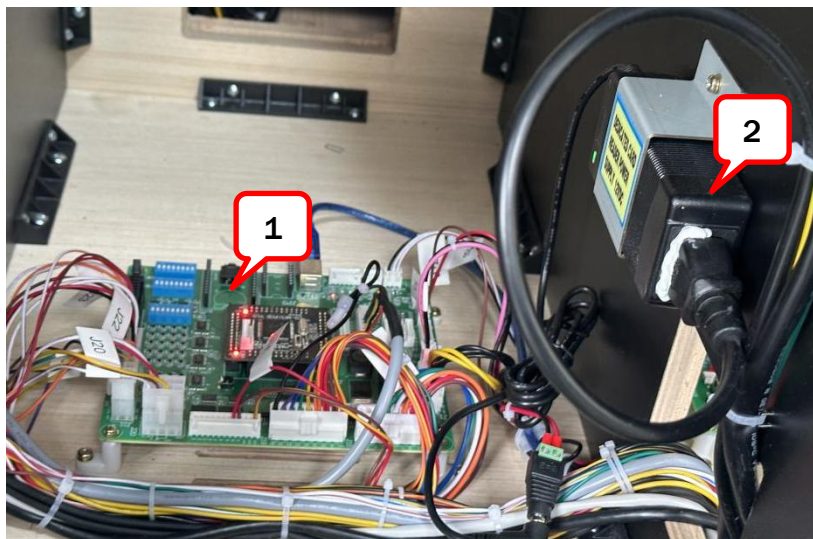

No.	Part No.	Code No.	Name	Version	Qty
1	L129-0626-00	297.9.0300003B	U3 mainboard	V1.1	1
	L129-0627-00	297.9.0300004B	MCU board	V1.1	1
2	L129-0610-00	2.16.03.000027	Adapter	V1.1	1

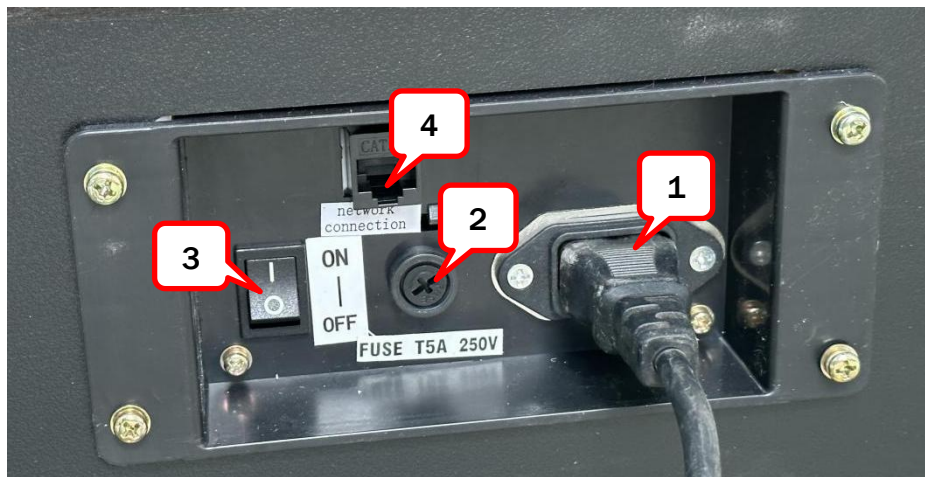

No.	Part No.	Code No.	Name	Version	Qty
1	L129-0617-00	2.32.01000001A	Filter	V1.1	1
2	L129-0619-00	2.19.01.000030	Fuse	V1.1	1
3	L129-0620-00	2.26.01.000005	Rocket SW	V1.1	1
4	L129-0622-00	2.33.02.000001	Network port	V1.1	1



No.	Part No.	Code No.	Name	Version	Qty
1	L129-0615-00	2.11.02000050D	PC	V1.1	1
2	L129-0630-00	2.11.07.020036	Dongle	V1.1	1
3	L129-0623-00	2.28.07.000003	Audio isolation	V1.1	1

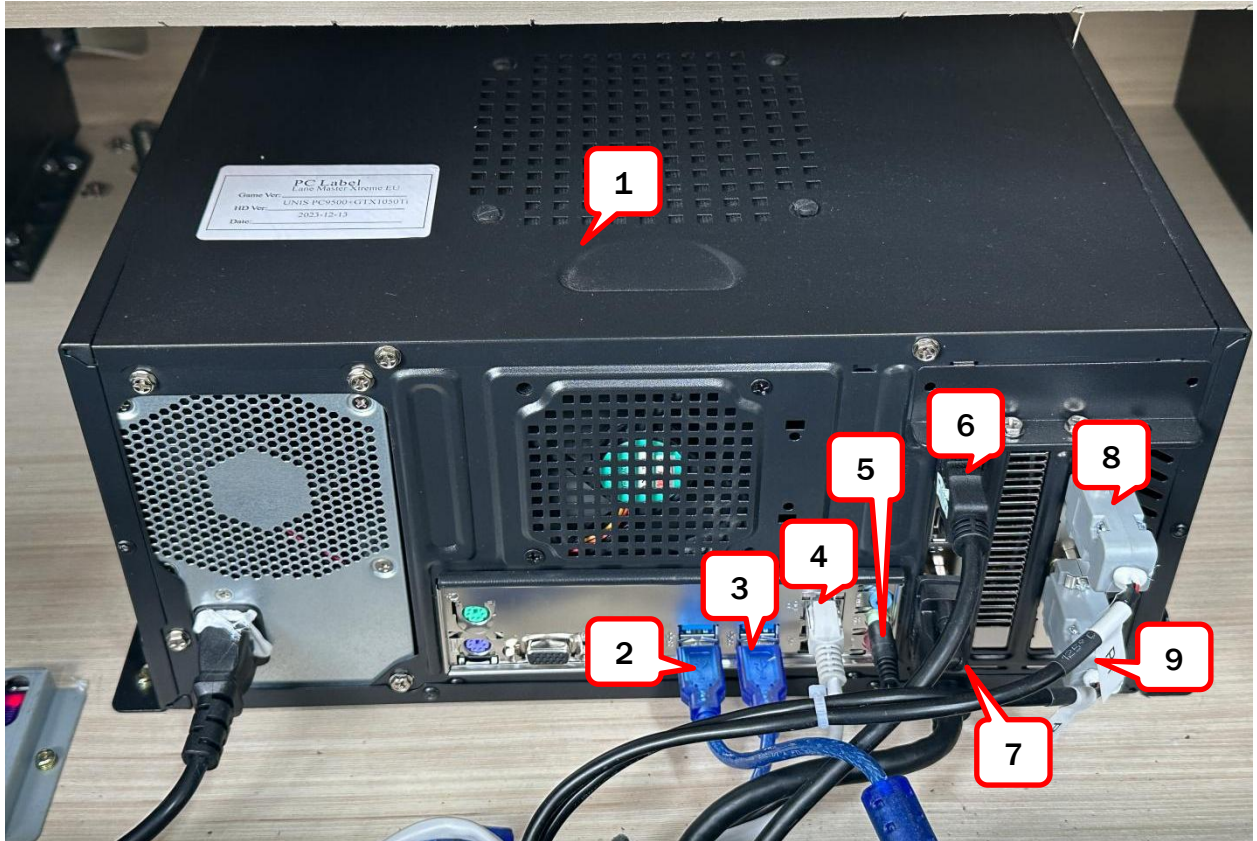

No.	Part No.	Code No.	Name	Version	Qty
1	L129-0615-00	2.11.02000050D	PC	V1.1	1
	L129-0663-00	2.11.07.090036	Memory	V1.1	1
	L129-0664-00	2.11.07.030106	Video card	V1.1	1
	L129-0665-00	2.11.07.220032	PC mainboard	V1.1	1
	L129-0666-00	2.66.01.090508	Hard disk	V1.1	1
	L129-0667-00	2.16.02.000106	PC power supply	V1.1	1
	L129-0668-00	2.11.07.190033	CPU	V1.1	1
	L129-0661-00	2.11.07.210038	Serial card	V1.1	1
2	L129-0607-00	2.33.04.030001	Extension cable	V1.1	1
3	L129-0675-00	2.33.04.000021	Cable	V1.1	1
4	L129-0608-00	2.33.02.000011	Network cable	V1.1	1
5	L129-0606-00	2.33.05.000010	Audio cable	V1.1	1
6	L129-0605-00	2.33.07.010012	HDMI-DVI cable	V1.1	1
7	L129-0604-00	2.33.07.000015A	DVI cable	V1.1	1
8	L129-0662-00	2.33.03.000017	Serial cable	V1.1	1
9	L129-0662-00	2.33.03.000017	Serial cable	V1.1	1

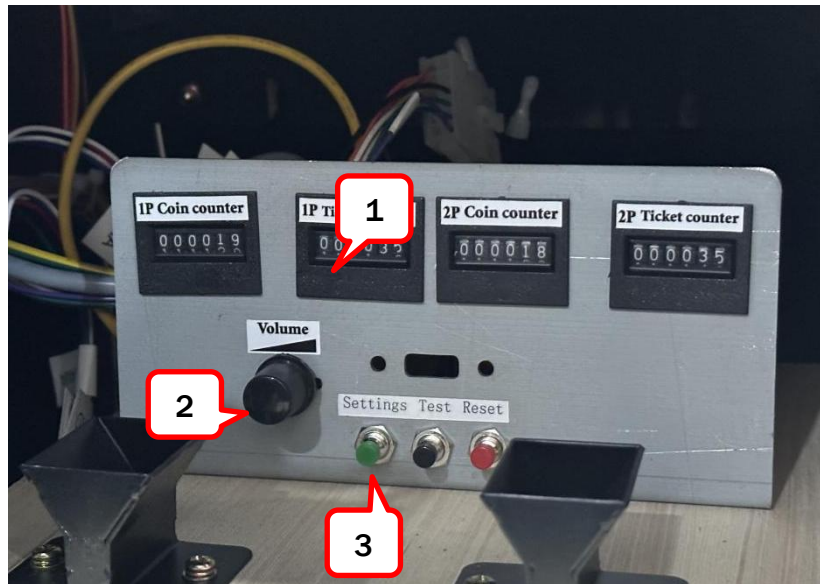

No.	Part No.	Code No.	Name	Version	Qty
1	L129-0643-00	2.30.00000006	Counter	V1.1	4
2	L129-0650-00	2.24.03.000001	Knob cover	V1.1	1
	L129-0651-00	297.9.1400001	POT board	V1.1	1
3	L129-0644-00	2.24.02.030002	Button(green)	V1.1	1
	L129-0645-00	2.24.02.050001	Button(black)	V1.1	1
	L129-0646-00	2.24.02.010002	Button(red)	V1.1	1

Send ball assy.

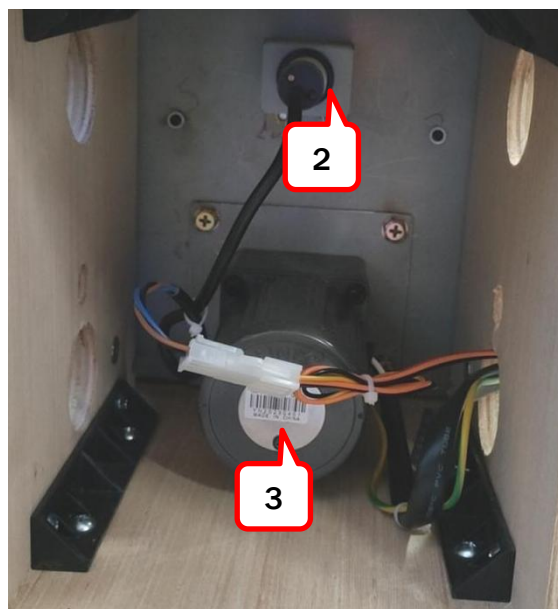
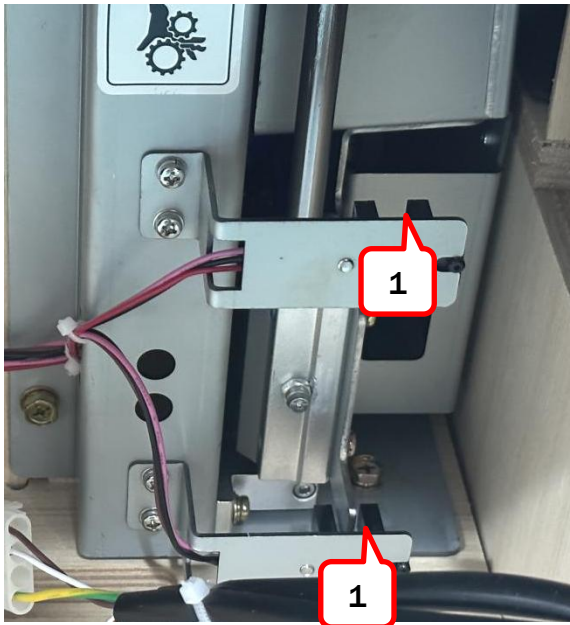

No.	Part No.	Code No.	Name	Version	Qty
1	L129-0640-00	2.15.01.000072	Slot sensor	V1.1	2
2	L129-0639-00	2.15.01.000048	Sensor	V1.1	1
3	L129-0307-00	2.34.05.000051	Motor	V1.1	1

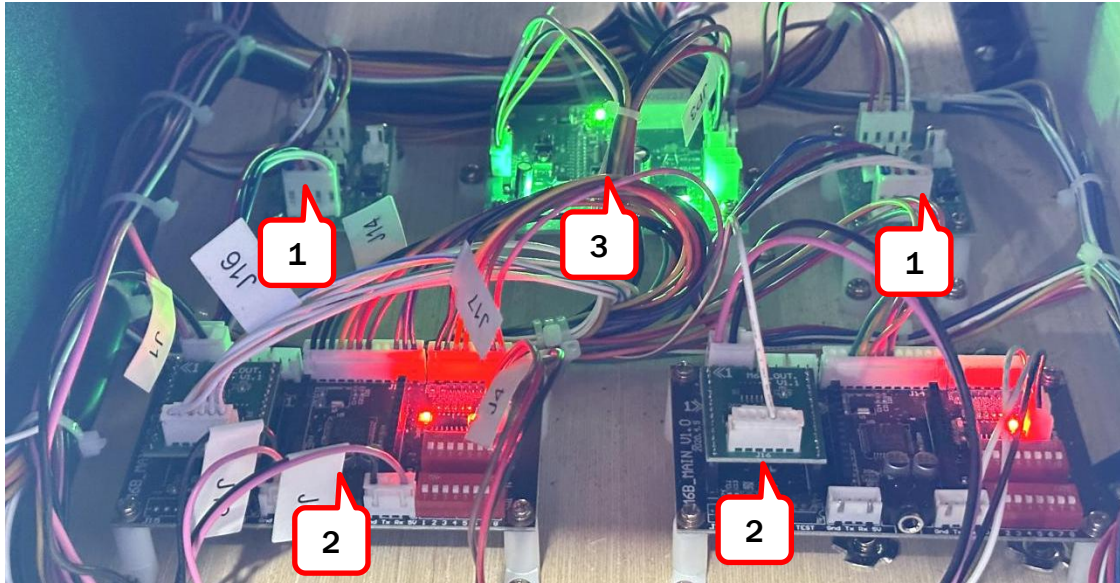

No.	Part No.	Code No.	Name	Version	Qty
1	L129-0652-00	297.9.0700002	Ticket convert board	V1.1	2
2	L129-0653-00	297.6.2008002	M6 mainboard	V1.1	2
	L129-0654-00	297.9.2011004	M6B board	V1.1	2
3	L129-0659-00	297.4.1801013	DC motor drive board	V1.1	1

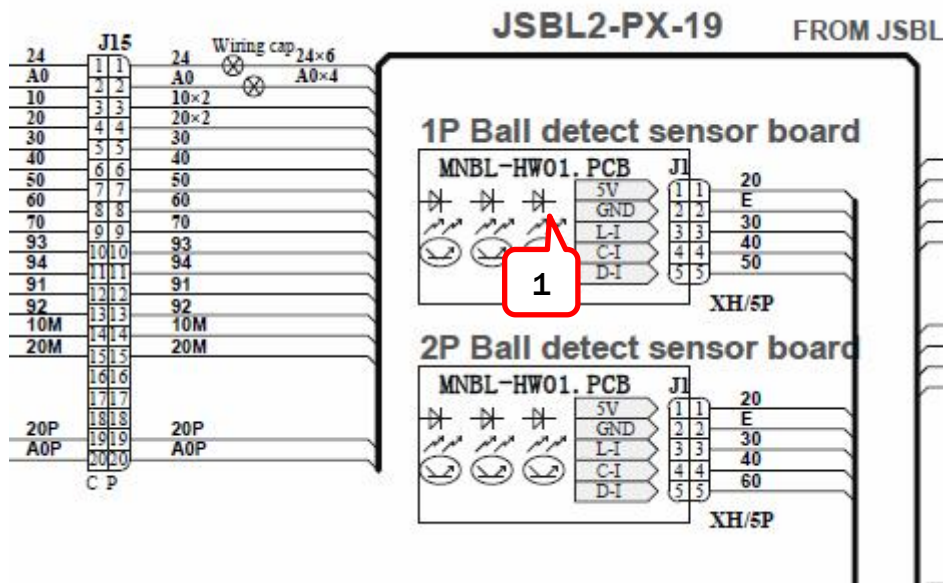

No.	Part No.	Code No.	Name	Version	Qty
1	L129-0628-00	297.9.2012007	Sensor board	V1.1	2

Hopper assy.:

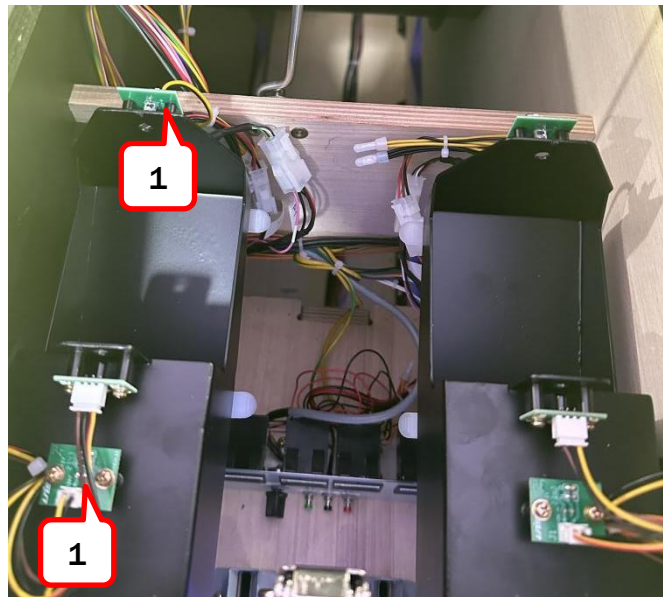

No.	Part No.	Code No.	Name	Version	Qty
1	L129-0657-00	297.9.2112002	Sensor board	V1.1	6

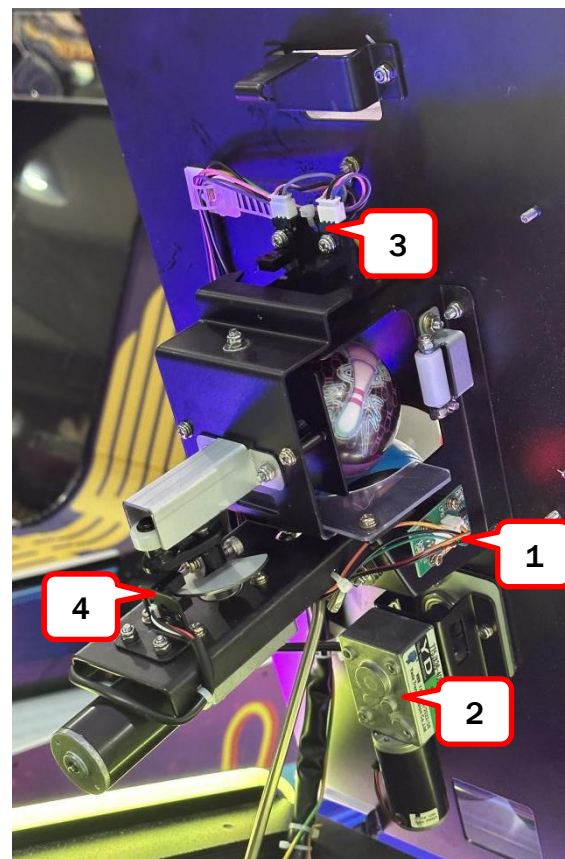
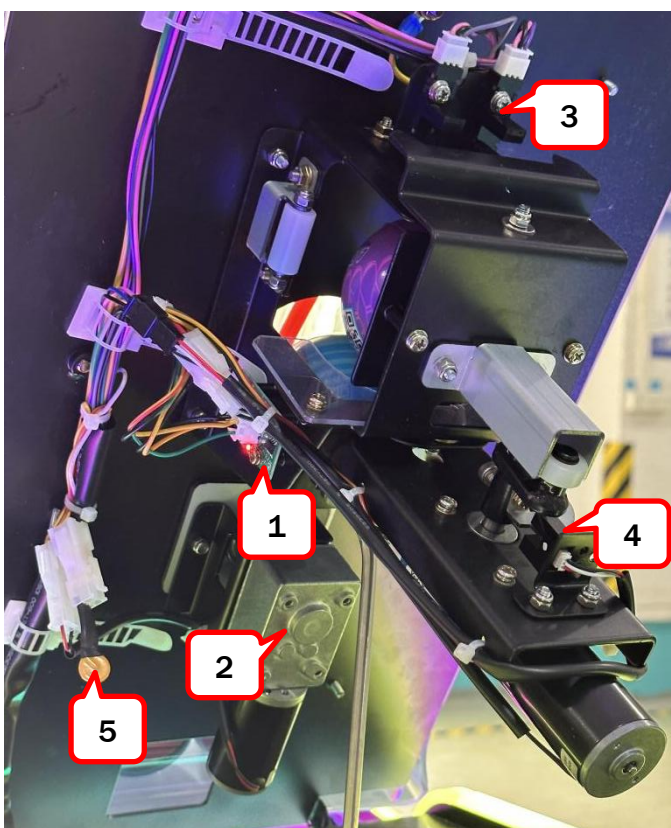

No.	Part No.	Code No.	Name	Version	Qty
1	L129-0657-00	297.9.2112002	Sensor board	V1.1	2
2	L129-0533-00	2.34.04.000265	DC motor	V1.1	2
3	L129-0640-00	2.15.01.000072	Slot sensor	V1.1	2
4	L129-0656-00	2.15.03.000054	Sensor	V1.1	1
5	L129-0658-00	2.19.03.000002A	4P port+fuse	V1.1	1

Monitor:

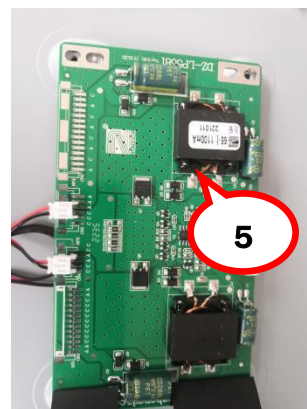
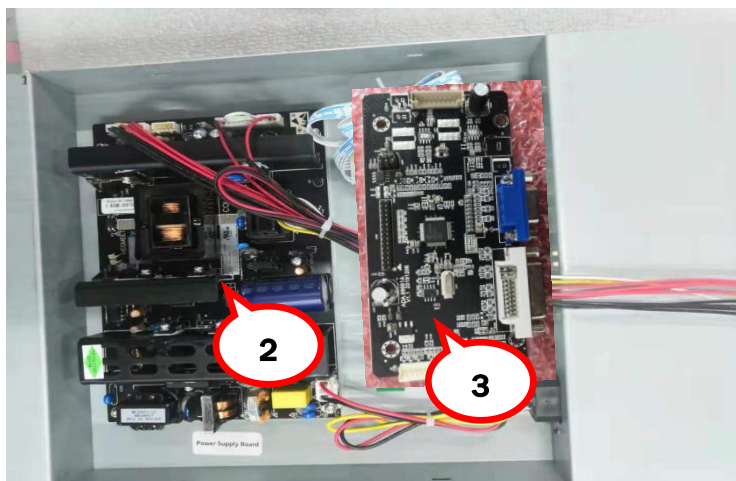

No.	Part No.	Code No.	Name	Version	Qty
1	L129-0670-00	2.12.04.030051	Logic board	1.1	1
2	L129-0673-00	2.12.04.030054	Power board	1.1	1
3	L129-0674-00	2.12.04.030055	Drive board	1.1	1
4	L129-0672-00	2.12.04.030053	Key board	1.1	1
5	L129-0671-00	2.12.04.030052	Converted board	1.1	1

www.unistechology.com

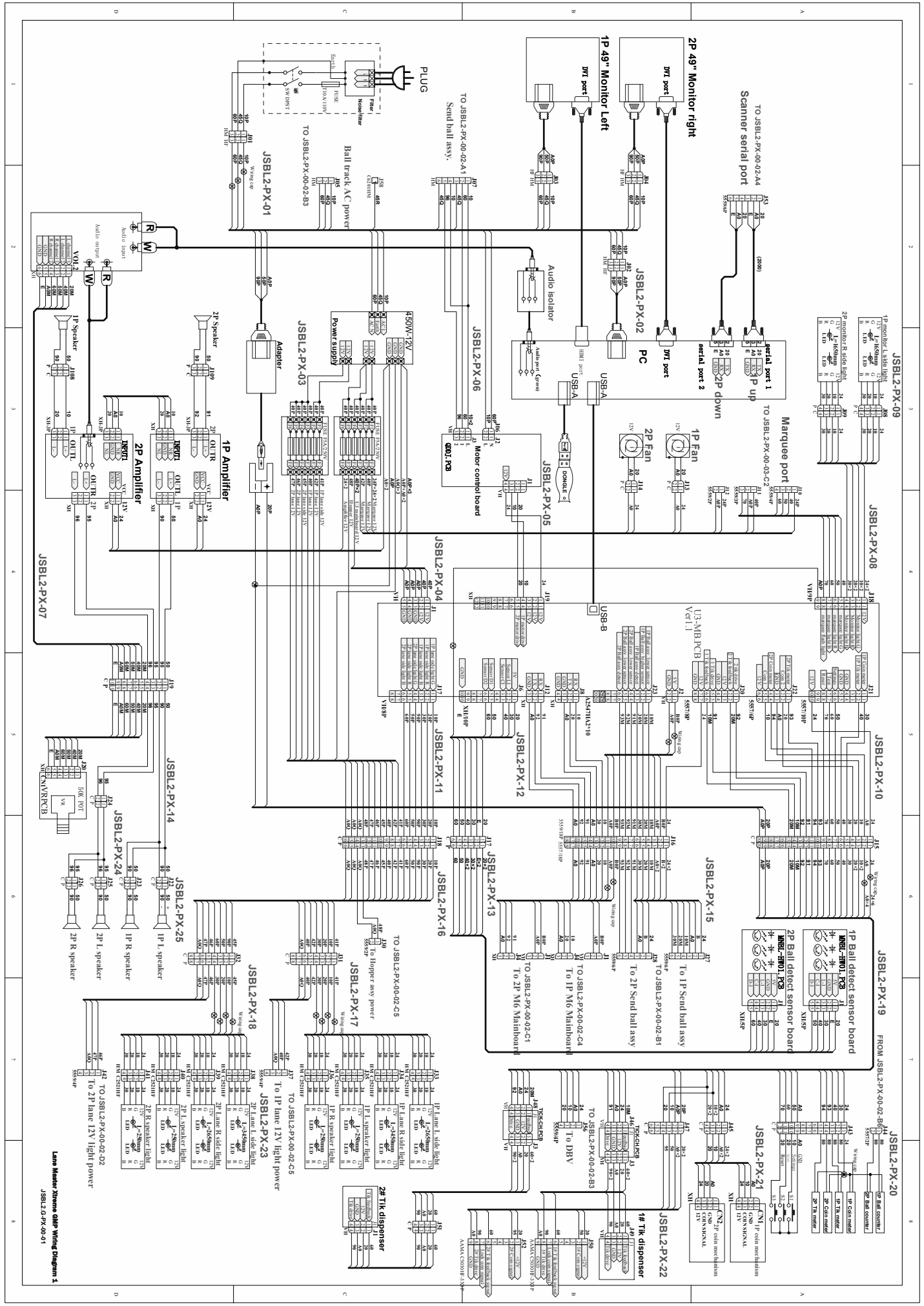

Lane Master Stereo AMP Wiring Diagram 1
 JSBL2-PX-01-01

