



CEC Version

 **Be Sure
to Read this
Manual
Before Use**



Operation Manual

Distributed by: Amusements Worldwide

www.amusementsworldwide.com

Tel: 214-750-9202

SERIAL NUMBER

DATE OF INSTALLATION

CONTENT

Important Safety Instructions	2
1. SPECIFICATIONS	4
2. PACKAGE CONTENTS.....	5
3. PART NAMES	6
4. SET UP & INSTALLATION.....	7
5. HOW TO PLAY	11
6. GAME OPTIONS	12
7. MAINTENANCE & INSPECTION.....	18
8. OVERALL CONSTRUCTION	19



WARNING

Non-technical personnel who do not have technical knowledge and Expertise should refrain from performing such work that this manual require or perform tasks which are not explained in this manual. Failing to comply can cause severe accidents such as electric shock or other serious injuries. All repairs must be performed to original manufacturer specifications.

WARNING: To reduce the risk of fire, electric shock or personal injury, unplug or disconnect the machine from the power supply before servicing.

Thank you for purchasing **DINO POP**. We hope you enjoy the product.

This manual contains valuable information about how to operate and maintain your game machine properly and safely. It is intended for the owner and/or personnel in charge of product operation. Carefully read and understand the instructions.

If you need any help during installation and setup please utilize this manual and troubleshooting guide. If the product fails to function properly, *non-technical personnel should under no circumstance attempt to service the machine*. Contact your distributor or manufacturer for help.

Before use, please read **IMPORTANT SAFETY INSTRUCTIONS**.

IMPORTANT SAFETY INSTRUCTIONS

To ensure the safe usage of this product, carefully read and understand these instructions before operating your game. Save these instructions for future reference.

Use this product only as described in this manual. Other uses not recommended may cause fire, electric shock or personal injury. Unplug the game from the outlet when not in use, when moving from one location to another, and before cleaning/servicing.

Explanations which require special attention are indicated by signs of warning. Depending on the potential hazardous degree, the terms: **NOTE**, **NOTICE**, and **WARNING** are used.

NOTE: A NOTE indicates useful hints or information about product usage.

NOTICE: A NOTICE indicates potential damage to product and how to avoid the problem.

WARNING: A WARNING indicates a potential for product damage or serious personal injury.

It is important to understand the meaning of the following HAZARD SIGNS before continuing:

High Voltage and Shock Hazard:

High voltage can cause electric shock.
Turn off/unplug power before servicing.



High Temperature Hazard:

This part may cause scalding.
Do not touch. Surface may be hot.



No Touching Hazard:

This part may be hot or can cause electric shock.

Do not touch.



Use the following safety guidelines to help ensure your own personal safety and to help protect your equipment and surrounding environment from potential damage.

 **This product is an indoor game machine. Do not install outdoors.**

Avoid installing in the following places to prevent fire, electric shock, injury and/or machine malfunctioning:

- Places subject to rain/moisture, or places subject to high humidity.
- Places subject to direct sunlight, or places subject to extremely hot or cold temperatures to ensure that it is used within the specified operating range.
- Places where inflammable gas may be present or in the vicinity of highly inflammable/volatile chemicals or items that can easily catch fire
- On unstable or sloped surfaces. The machine may topple or cause unforeseen accidents.
- Vicinity of fire exits, fire extinguishers etc that may block/prevent safety measures

IMPORTANT NOTE:

ALL REPAIRS MUST BE DONE TO ORIGINAL MANUFACTURER SPECIFICATIONS. FAILURE TO DO SO VOID ALL WARRANTIES AND OPERATOR ASSUMES ALL RISKS.

Note: The contents of this manual may be updated without notice

1. SPECIFICATIONS

- Rated power supply: 110V, 50/60Hz
Min. Power consumption: 140W
Max. Power consumption: 160W
Dimensions: D71.65×W28.74×H77.48 (inches)
Weight: Approximately 396.83 (lbs)

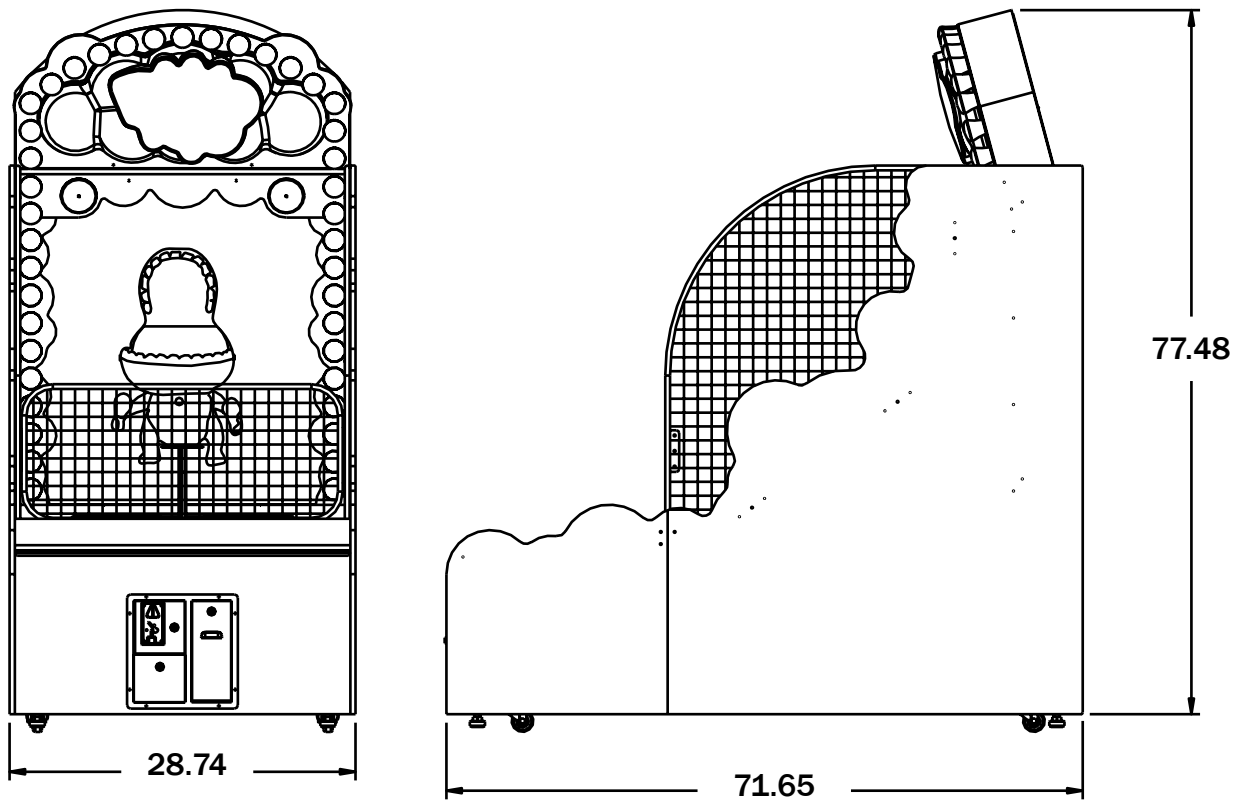

Note: Game parameters are subject to change without notice.

! **NOTICE:** After turning off the game, please wait at least 1 minute before restarting again.

2. PACKAGE CONTENTS

Open the package and make sure all the items are included:

- 1 x Body Assembly
- Following accessories

No.	Part No.	Name	Spec.	Qty.	Illustration	Note
1	D109-804-000	AC power	10A/250V 1.8m	1		
2	D109-426-000	Fuse	T6A/125V Φ5-20mm	1		
3	D109-733-000	Manual	English	1		
4	D109-435	Ball	VBS75	50		
5	D109-409-000	Key	C582	2		
Tot.				55		

If any items are found to be missing, please contact your sales representative for help immediately.

Warranty: Universal Space provides 90 days warranty for all electrical and mechanical components, when used under normal operating conditions. Any modification or abuse of these items immediately voids the warranty. Graphic and consumable items are exempt from any warranty.

NOTE: Part models are subject to change without notice.

3. PART NAMES

FRONT VIEW

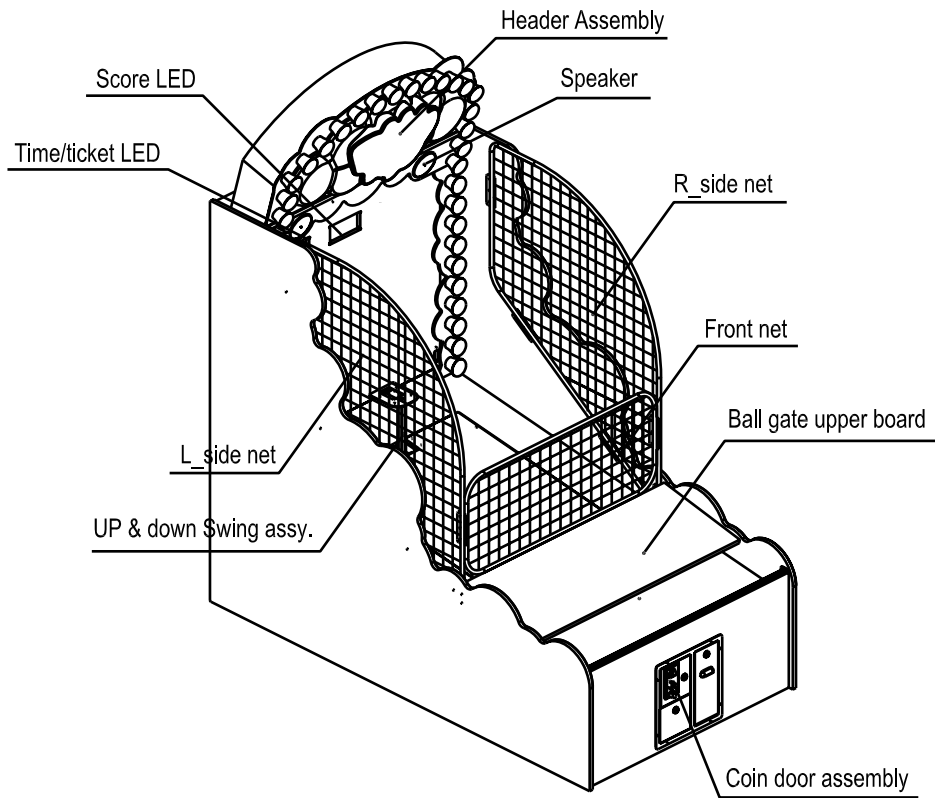

REAR VIEW

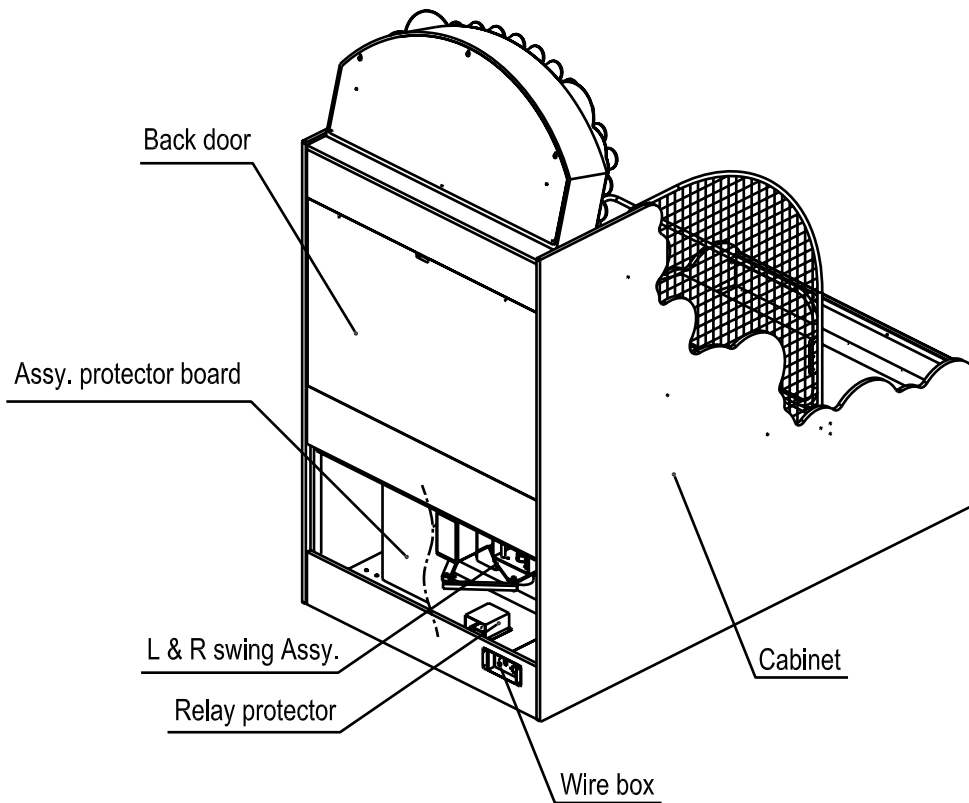

4. SET UP & INSTALLATION

 **This product is an indoor game machine. Do not install outdoors.**

- Refer to IMPORTANT SAFETY INSTRUCTIONS (Pg. 2) for places to avoid
- Place the unit on a dry level surface
- Ventilation openings in the back of the unit must not be obstructed by objects or by wall.

4.1 Play Zone

This machine requires space for playing and for maintenance as shown below.
Leave space around the game upon installation:

Service area: 20 inches
Play area: 40 inches

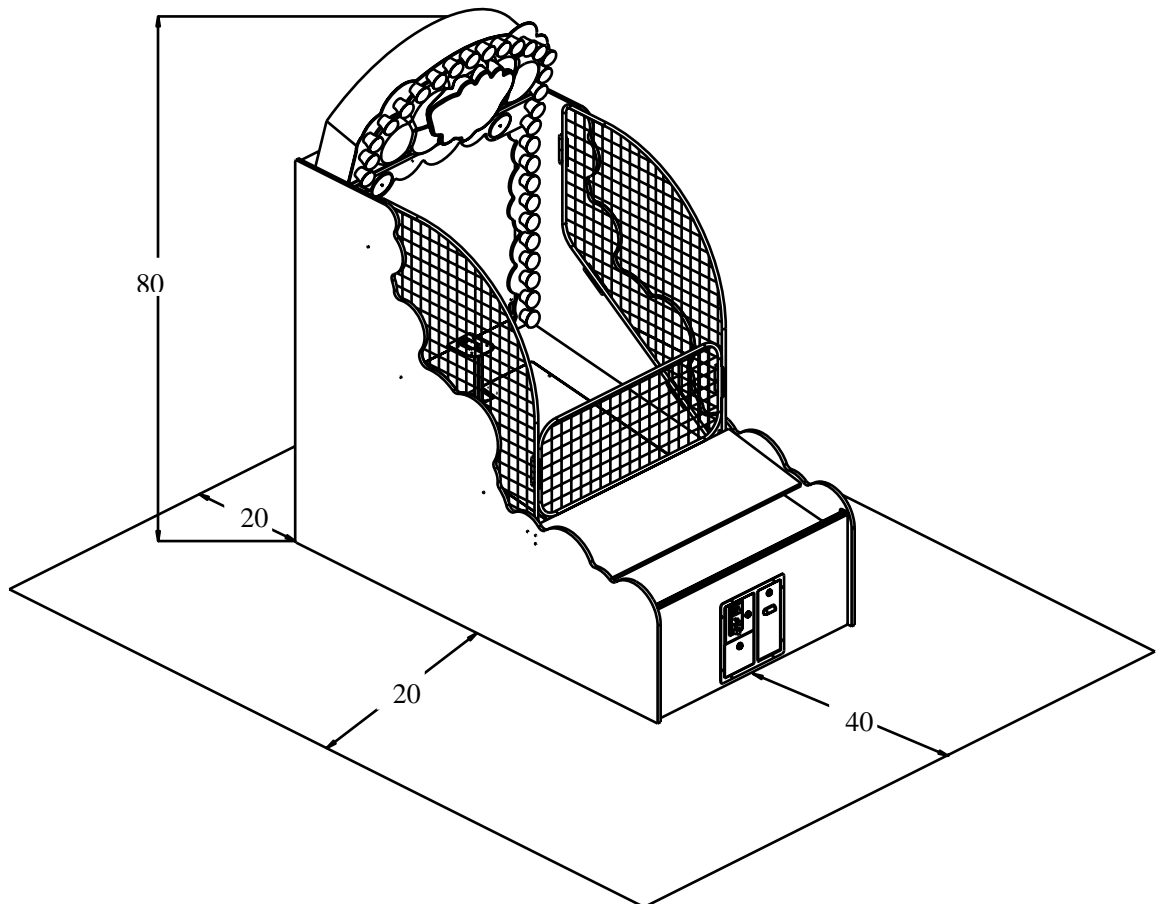

4.2 Level Adjustment

Install this machine on a flat surface. Adjust levers to lift casters off the ground to level the game. If the game is installed on an unsuitable floor, it could cause game malfunction.

To secure the game, adjust the Leveler down until it touches the floor, lifting the casters off the ground by 5mm. Repeat the same for all levelers.

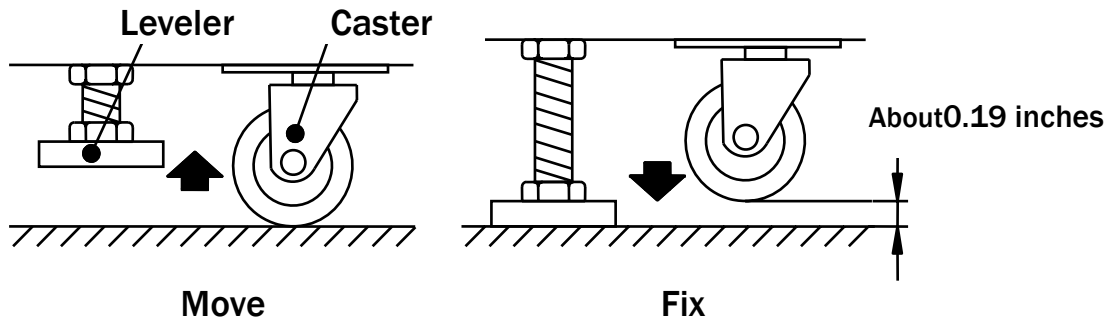

NOTICE

Make sure the machine is level with the ground and all the adjustable legs should stick to the floor closely.

4.3 Transporting the Game

If you need to move the game, adjust the levelers back to an “up” position so the casters touch the ground.

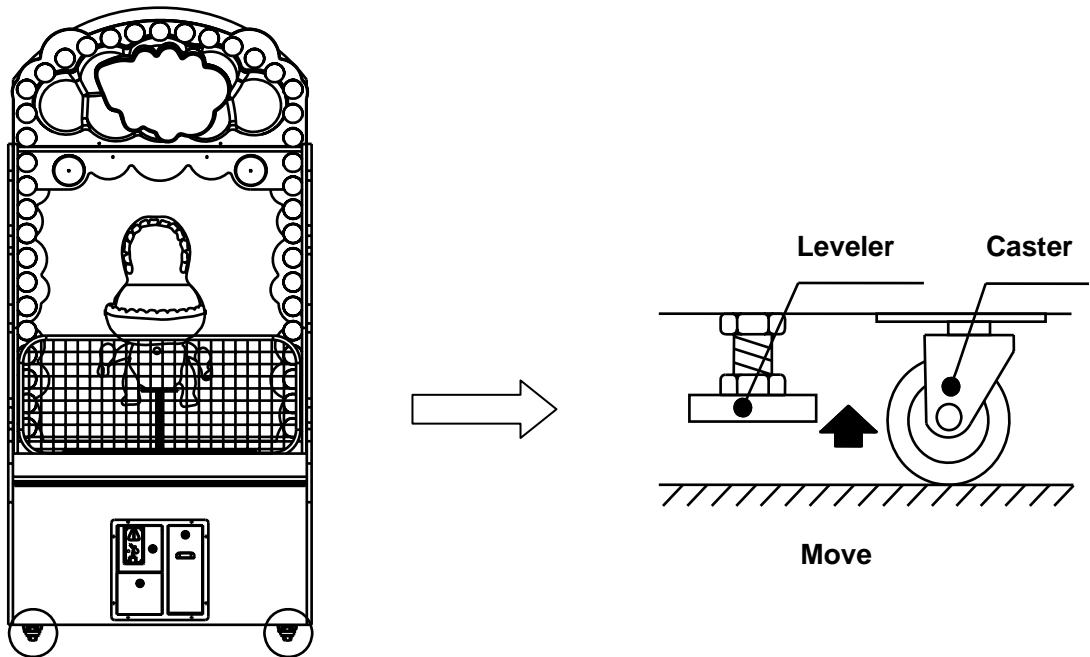

NOTICE

- Be careful not to damage the machine during transport.
- The machine should be handled with care when bringing it down from a higher level.
- Always unplug the game before moving.
- Keep the machine in upright position during transport.
- For longer distance transport, package the game properly to prevent damages

4.4 Connecting Power

! **WARNING:** Check the voltage rating before you connect the equipment to an electrical outlet to ensure that the required voltage and frequency match the available power source. Please refer the label of the machine.

- Do not plug the equipment power cables into an electrical outlet if the power cable is damaged.
- Avoid putting many loads on one electrical outlet as it could generate heat and fire resulting from overload.
- Connect the grounding conductor to the earth terminal (GND):

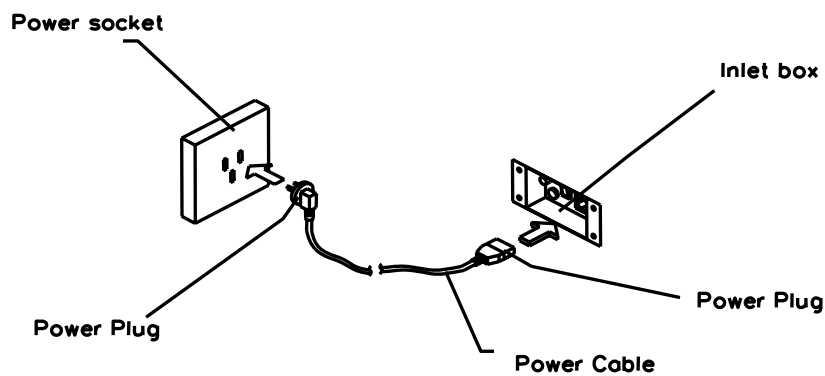

! **WARNING**

Ensure no heavy objects rest on the power cord. Check to make sure the game cabinet does not sit on the power cord as this could damage the cord and become hazardous.

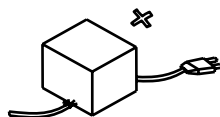

To disconnect the game, grip the plug and pull it from the wall outlet. Never pull by the cord.

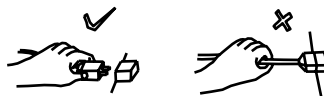

To prevent electric shock, do not touch the power plug when hand is wet.



Ensure that nothing rests on the power cord and that it is not located where it can be stepped on or tripped over.



5. HOW TO PLAY

- ✧ INSERT COIN(S), BALLS ARE RELEASED AND GAME STARTS AUTOMATICALLY.
- ✧ DINO WILL MOVE UP, DOWN, LEFT AND RIGHT. TOSS AS MANY BALLS AS POSSIBLE INTO THE DINO'S MOUTH TO EARN POINTS BEFORE THE TIME RUNS OUT.
- ✧ BEAT THE BONUS SCORE TO WIN THE BONUS
- ✧ TICKET WILL BE AWARDED AT THE END OF THE GAME BASED ON FINAL SCORE.



6. GAME OPTIONS

6.1 Switches Control Signal

Refer to the attached I/O chart and the schematic.

To adjust DIP, please refer to the I/O chart. The initial setting is in CAPITAL LETTER.

Main board :

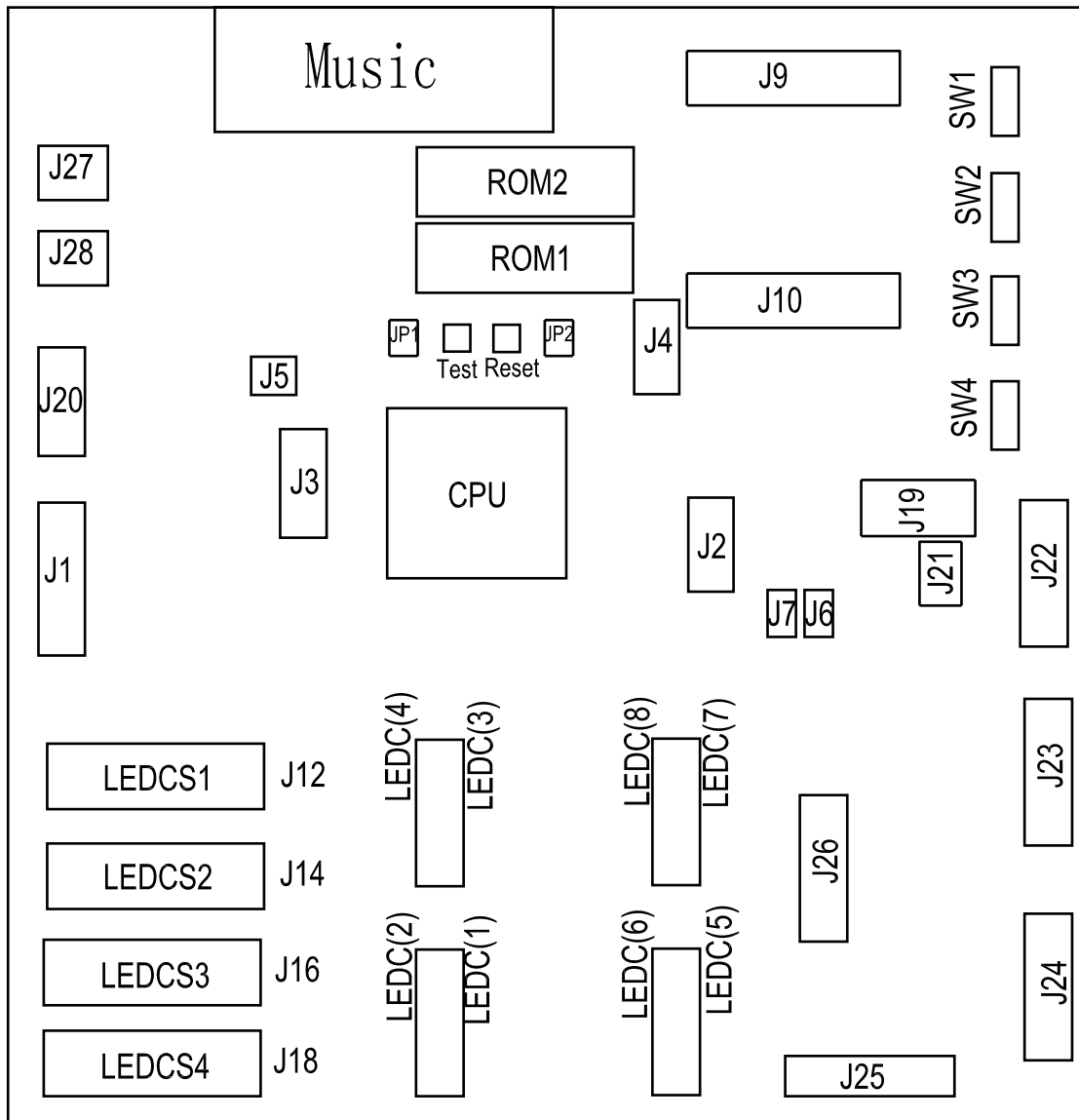

To enter Test Mode:

Press the TEST button found on the main board.

LED Display:

BONUS LED<2>3-1 Time LED<1>7-5 Score LED<1>3-1

Test method:

Testing LED displays is normal or not when it shows < 1.2.3.4.5.6.7.8.>

Press TEST button again and LED displays 1, it shows DIP SW state.

Press TEST button again and LED displays 2, it shows the number of on-off SW

Press TEST button again and LED displays 3. Press reset and service button to test music.

Press TEST button and LED displays 4. Hold IN1-40 and it shows OUT1-40 corresponding lighting output.

Press TEST button again and LED displays 5, light move slowly.

ERROR CODE:

The following error codes will display if the input signal is abnormal after turning on the game (but continues to operate after alarm goes off).

E01 Ticket Assy. Reset error

E02 Score sensor error

E03 Ball gate sensor error

E04 Service button error

E05 Test button error

E83 Coin mech error

E84 Coin mech error

6.2 DIP adjust (Default Setting)

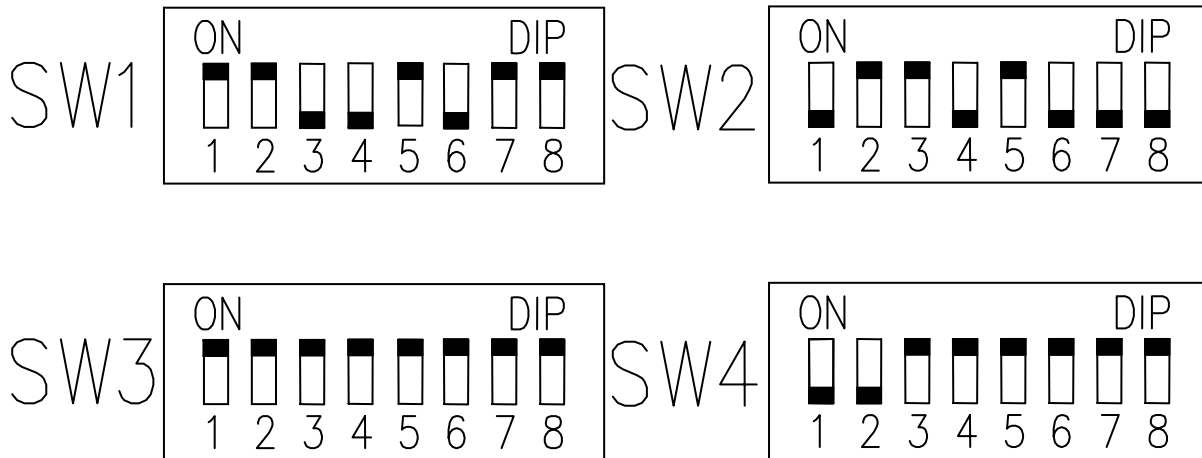

Notice

The above are subject to change without notice.

6.3 Parameter Setting

Default settings are in capital letters.

DIP Adjust 1 (SW1)

(1) Coin(s) per game

Item	Content	DIP Adjust (SW1)		Note
		1	2	
Coin(s) per game	1	ON	ON	
	2	off	on	
	3	on	off	
	4	off	off	

(2) Game play time(s)

Item	Content	DIP Adjust (SW1)			Note
		3	4	5	
Game play time(s)	30	on	on	on	
	35	off	on	on	
	40	on	off	on	
	45	OFF	OFF	ON	
	50	on	on	off	
	60	off	on	off	
	75	on	off	off	
	100	off	off	off	

(3) Mercy ticket

Item	Content	DIP Adjust (SW1)		Note
		6	7	
Mercy ticket	0	on	on	
	1	OFF	ON	
	2	on	off	
	3	off	off	

(4) Score memory

Item	Content	DIP Adjust (SW1)	Note
		8	
Score memory	Yes	ON	
	No	off	

DIP Adjust 2 (SW2)

(5) Score per ball

Item	Content	DIP Adjust (SW2)		Note
		1	2	
Score per ball	1	on	on	
	2	OFF	ON	
	5	on	off	
	10	off	off	

(6) Score per ticket

Item	Content	DIP Adjust (SW2)			Note
		3	4	5	
Score per ticket	5	on	on	on	
	8	off	on	on	
	10	ON	OFF	ON	
	15	off	off	on	
	20	on	on	off	
	25	off	on	off	
	30	on	off	off	
	50	off	off	off	

DIP Adjust 4 (SW4)

(7) Ticket payout max

Item	Content	SW4_DIP				
		1	2	3	4	5
Ticket payout max	0	on	on	on	on	on
	1	off	on	on	on	on
	2	on	off	on	on	on
	3	OFF	OFF	ON	ON	ON
	4	on	on	off	on	on
	5	off	on	off	on	on
	6	on	off	off	on	on
	7	off	off	off	on	on
	8	on	on	on	off	on
	10	off	on	on	off	on
	12	on	off	on	off	on
	14	off	off	on	off	on
	16	on	on	off	off	on
	18	off	on	off	off	on
	20	on	off	off	off	on
MORE	off	off	off	off	on	

(8) Fix ticket

Item	Content	SW4_DIP				
		1	2	3	4	5
Fix Ticket	1	off	on	on	on	off
	2	on	off	on	on	off
	3	off	off	on	on	off
	4	on	on	off	on	off
	5	off	on	off	on	off
	6	on	off	off	on	off
	7	off	off	off	on	off
	8	on	on	on	off	off
	10	off	on	on	off	off

(9) Attract mode

Item	Content	DIP Adjust(SW4)		Note
		6	7	
Attract mode	YES	ON	ON	
	YES w/t motion	off	on	
	NO	on	off	

Input & output parts:

Input part:

INPUT	CONTENT
J9-1	Ticket reset
J9-2	Score sensor
J9-3	Ball gate SW
J9-4	
J9-5	
J9-6	
J9-7	

Output part:

OUTPUT	CONTENT	OUTPUT	CONTENT	OUTPUT	CONTENT
J22-1	Lighting 1	J23-9	Ball gate motor	J4-1	
J22-2	Lighting 2	J23-10	Motor L&R	J4-2	
J22-3	Lighting 3	J23-11	Motor U&D	J4-3	LAT
J22-4	Lighting 4	J23-12		J4-4	CLOCK
J22-5		J23-13		J4-5	DATA

OUTPUT	CONTENT	OUTPUT	CONTENT	OUTPUT	CONTENT	OUTPUT	CONTENT
J20-1	POT_L①	J19-1	1#Coin lock	J21-1	Ticket Assy. drive	J27-1	Speaker _L+
J20-2	POT_L②	J19-2	1#SW signal	J21-2	Ticket Assy. signal	J27-2	Speaker _L-
J20-3	POT_R①	J19-3	GND	J21-3	12V	J28-1	Speaker _R+
J20-4	POT_R②	J19-4		J21-4	GND	J28-2	Speaker _R-
J20-5	POT_L③	J19-5		J21-5		Counter	
J20-6	POT_R③	J19-6	12V	J21-6		J8-1	+12V
				J21-7		J8-2	+12V
				J21-8		J8-3	Coin counter
						J8-4	Ticket counter

7. MAINTENANCE, INSPECTION

7.1 Safety Check

Check the points listed before operating the machine. These checks are necessary for safe machine operation:

1. Try to run the game before operation each day.
2. Conduct monthly routine checks of game components ensure good working condition
3. Check the machine regularly for dust and clean when necessary.

Note: Parts and components require preventative maintenance to be kept running smoothly

7.2 Handling Precautions

When installing or inspecting the machine, be very careful of the following points and pay attention to ensure that the player can enjoy the game safely.

Non-compliance with the following points or inappropriate handling running counter to the cautionary matters herein stated can cause personal injury or damage to the machine



WARNING

- Before servicing the machine, off. Servicing without turning the
power off can cause electric shock or short circuit.
- To avoid electric shock or short circuit, do not plug then unplug the power quickly
- Do not expose power cords and earth wires, these are susceptible to damage.
- Damaged cords and wires can cause electric shock or short circuit and should be replaced immediately.
- When or after installing the product, avoid pulling the power cord to prevent unnecessary wear and tear. Use the power button to disconnect power.
- In case the power cord is damaged, ask for replacement through where the product was purchased from or replace locally. Continued usage of damaged cord can cause fire, electric shock or leakage.
- Perform grounding appropriately. Inappropriate grounding can cause electric shock.
- Use fuses that meet specified rating. Fuses exceeding can cause an electric shock.
- Should a problem occur, turn off the power immediately and stop operating the machine. Unplug the power cord of the service outlet. Operating the machine without correcting the problem may cause a fire or injuries.
- Insert the power plug securely into the outlet. Poor contact may cause overheating, resulting in fire or burns.
- To ensure the warning labels attached on the machine are visible and legible, install the machine in a well-lit location, and keep the labels clean at all times. Make sure the labels are not hidden behind other game machines.

8. OVERALL CONSTRUCTION

8.1 Main Assembly 1:

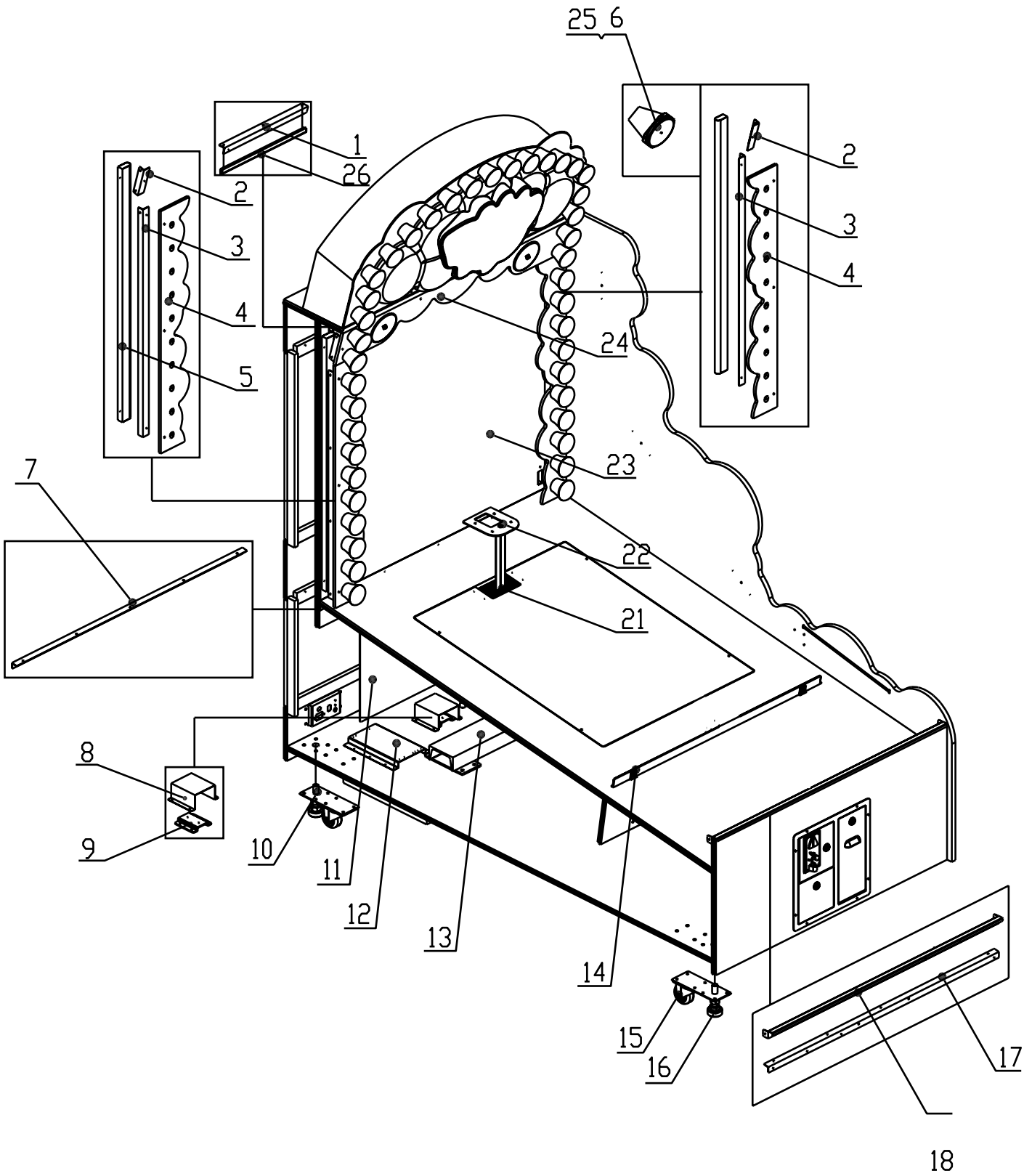

No.	Part No.	Name	Qty.
1	D109-101-000	LED upper holder	1
2	D109-102-000	LED L&R holder 1	2
3	D109-103-000	LED L&R holder 2	2
4	D109-501-000	LED L&R board	2
5	D109-401-000	T5 daylight lamp	2
6	D109-104-000	Speaker net	2
7	D109-105-000	Fixation board B	1
8	D109-601-000	Protect cover	1
9	D109-107-000	Relay holder	1
10	D109-108-000	Leveler	4
11	D109-602-000	Assy. Protect board	1
12	D109-109-000	Power supply holder	1
13	D109-001-000	L&R swing Assy.	1
14	D109-002-000	Ball gate Assy.	1
15	D109-402-000	Castor	4
16	D109-110-000	Leveler bracket	1
17	D109-111-000	Fixation board A	1
18	D109-112-000	Fixation board B	1
21	D109-113-000	Playfield ornament	1
22	D109-003-000	U&D swing Assy.	1
23	D109-603-000	LED menu	1
24	D109-502-000	LED upper board	1
25	D109-403-000	Speaker	2
26	D109-404-000	T5 daylight lamp	1

8.2 Cabinet:

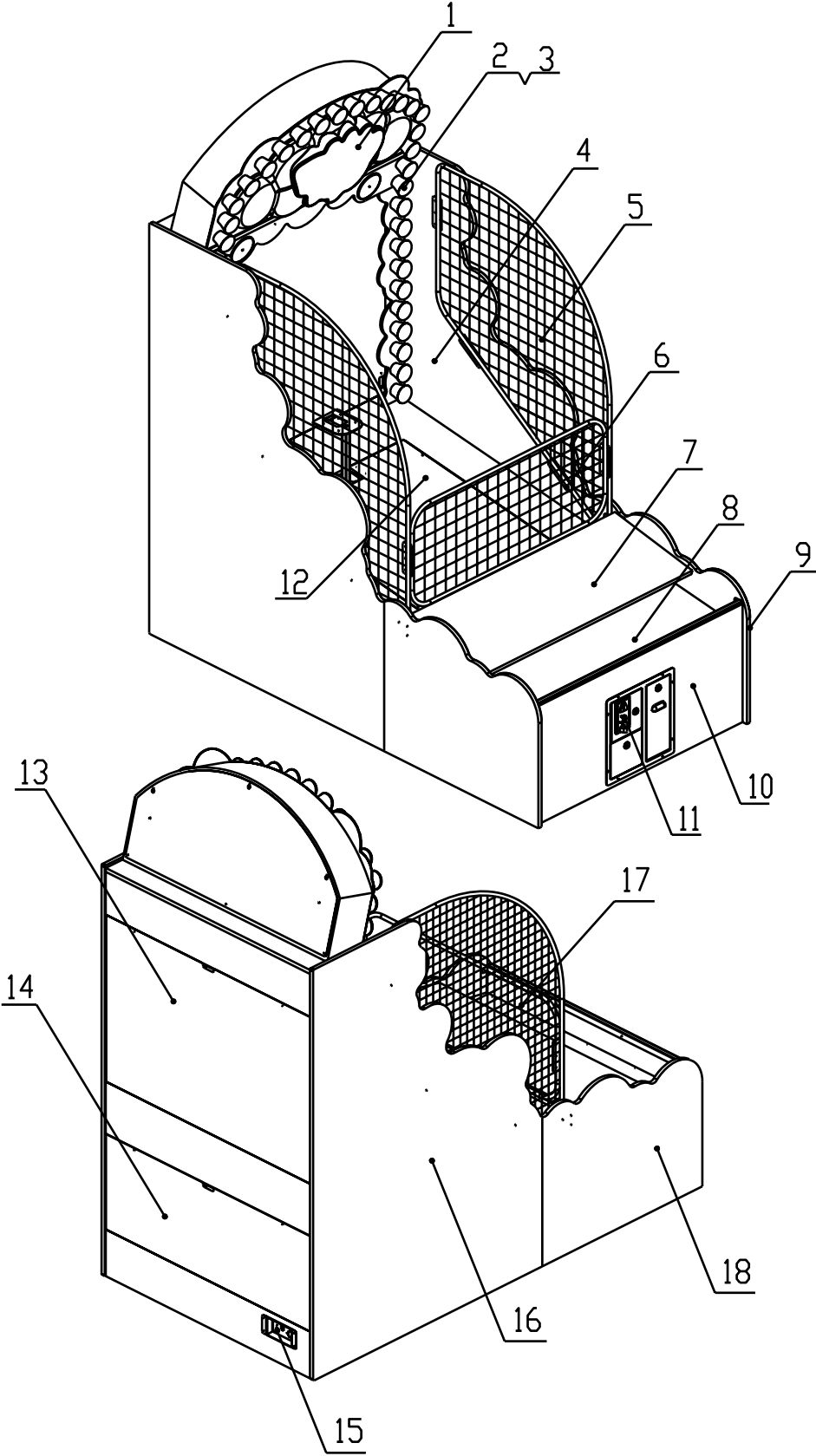

No.	Part No.	Name	Qty.
1	D109-003-000	Header Assy.	1
2	D109-405-000	Φ60 lamp-chimney	41
3	D109-406-000	LED lamp	14
	D109-407-000	LED lamp	13
	D109-408-000	LED lamp	14
4	D109-503-000	R_back board	1
5	D109-114-000	R_side net	1
6	D109-115-000	Front net	1
7	D109-504-000	Ball gate board	1
8	D109-505-000	Playfield 1	1
9	D109-506-000	R_front board	1
10	D109-507-000	Front board	1
11	D109-004-000	Coin door Assy.	1
12	D109-508-000	Playfield 2	1
13	D109-509-000	U_back door	1
14	D109-510-000	D_back door	1
15	D109-116-000	Wire box bracket	1
16	D109-511-000	L_back board	1
17	D109-117-000	L_side net	1
18	D109-512-000	L_front board	1

8.3 Coin door Assembly

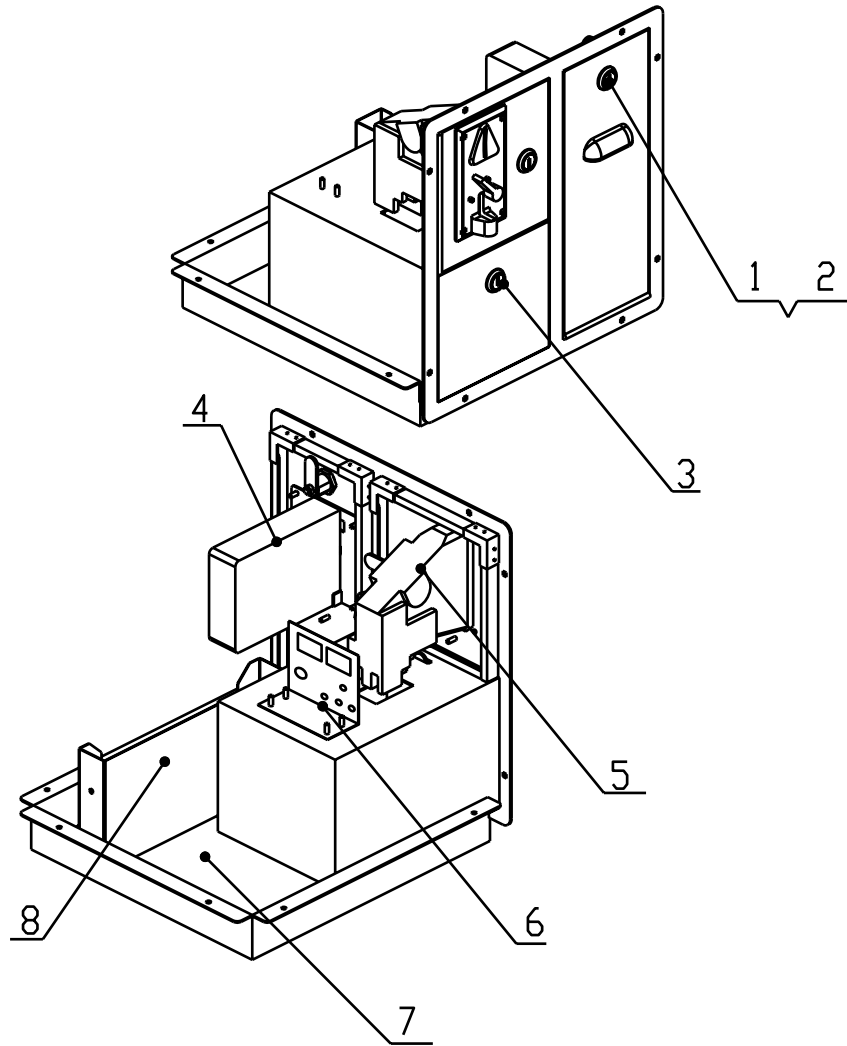

No.	Part No.	Name	Qty.
1	D109-409-000	Lock	2
2	D109-118-000	Lock board	2
3	D109-410-000	Lock	1
4	D109-411-000	Ticket machine	1
5	D109-412-000	Coin machine	1
6	D109-119-000	Counter install board A	
7	D109-120-000	Connect board	1
8	D109-121-000	Ticket box 120	1

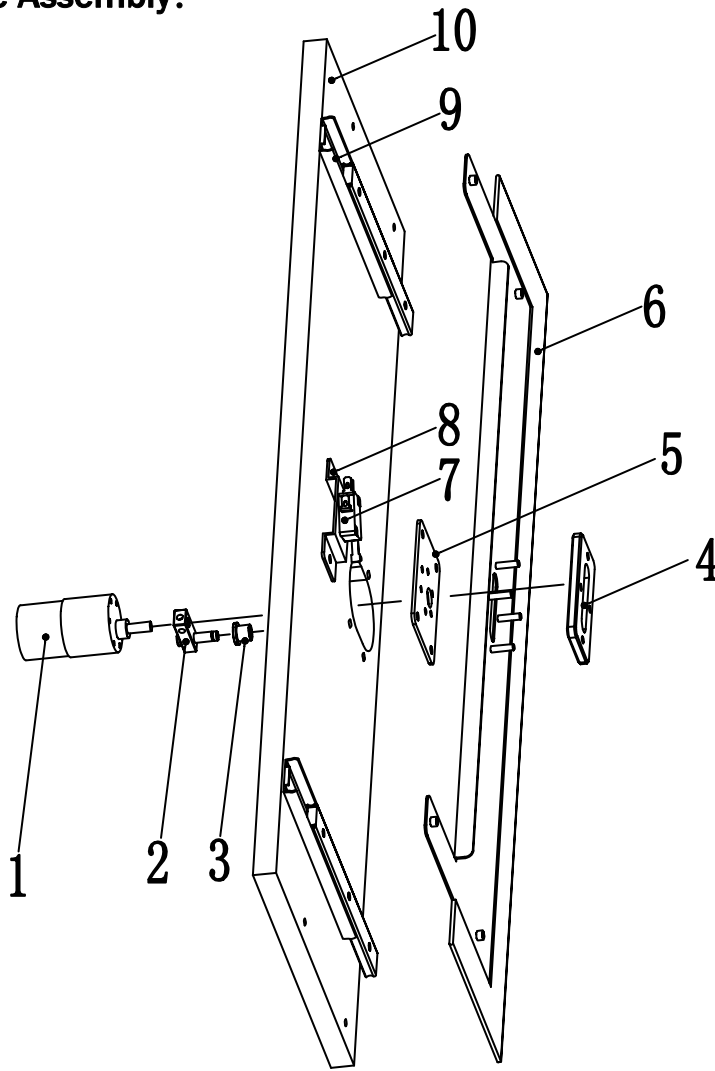
8.4 Ball Gate Assembly:

No.	Part No.	Name	Qty.
1	D109-122-000	DC motor	1
2	D109-123-000	Crank	1
3	D109-414-000	Clip	1
4	D109-604-000	Moving board Black	1
5	D109-124-000	Motor fixation board	1
6	D109-125-000	Fixation board	1
7	D109-415-000	Micro. SW	
8	D109-126-000	SW bracket	1
9	D109-127-000	Guide track	2
10	D109-513-000	Ball gate board	1

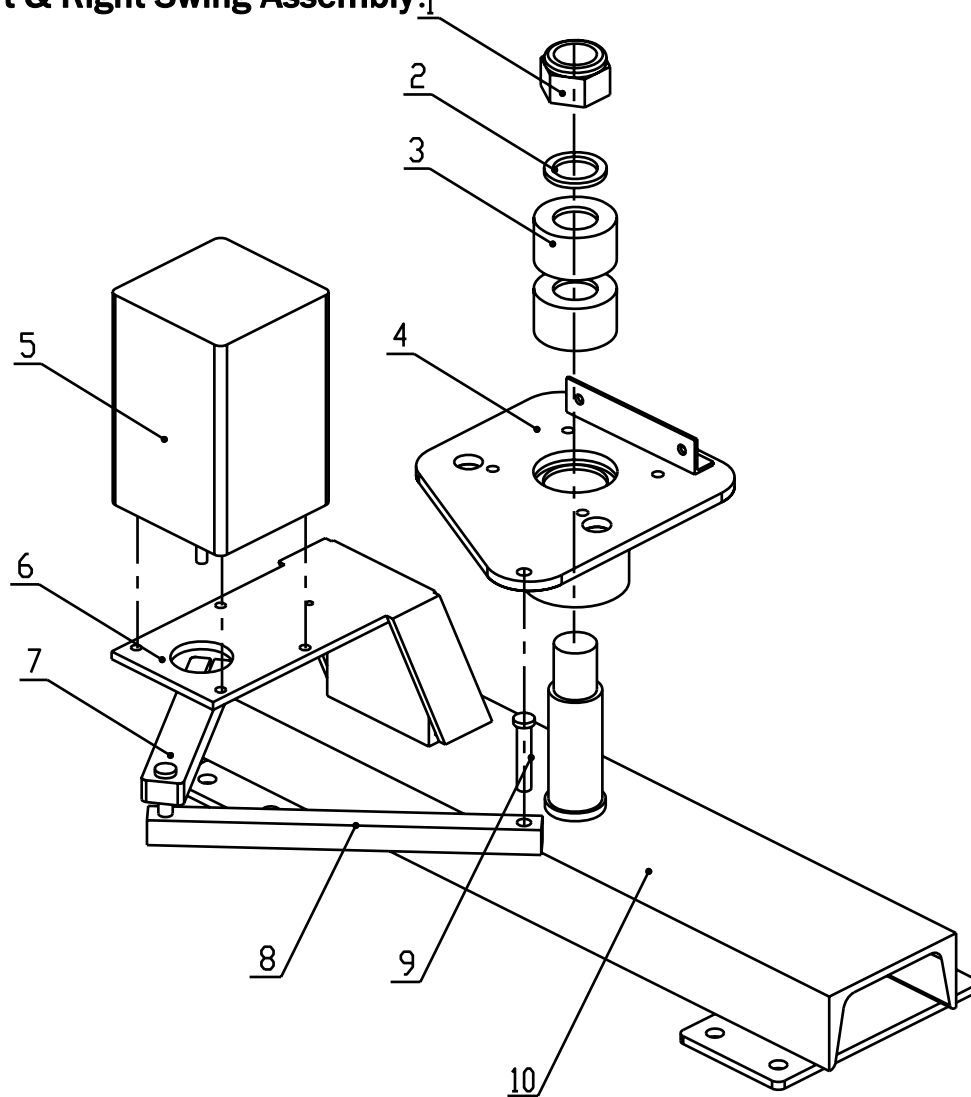
8.5 Left & Right Swing Assembly:

No.	Part No.	Name	Qty.
1	D109-128-000	Nut	1
2	D109-129-000	Washer	1
3	D109-416-000	Bearing	2
4	D109-130-000	Rotation pole	1
5	D109-417-000	single-phase Motor	1
6	D109-131-000	Motor holder	1
7	D109-132-000	Rocker_arm A	1
8	D109-132-000	Connect pole A	1
9	D109-418-000	Bearing	2
10	D109-133-000	Assy. install bracket	1

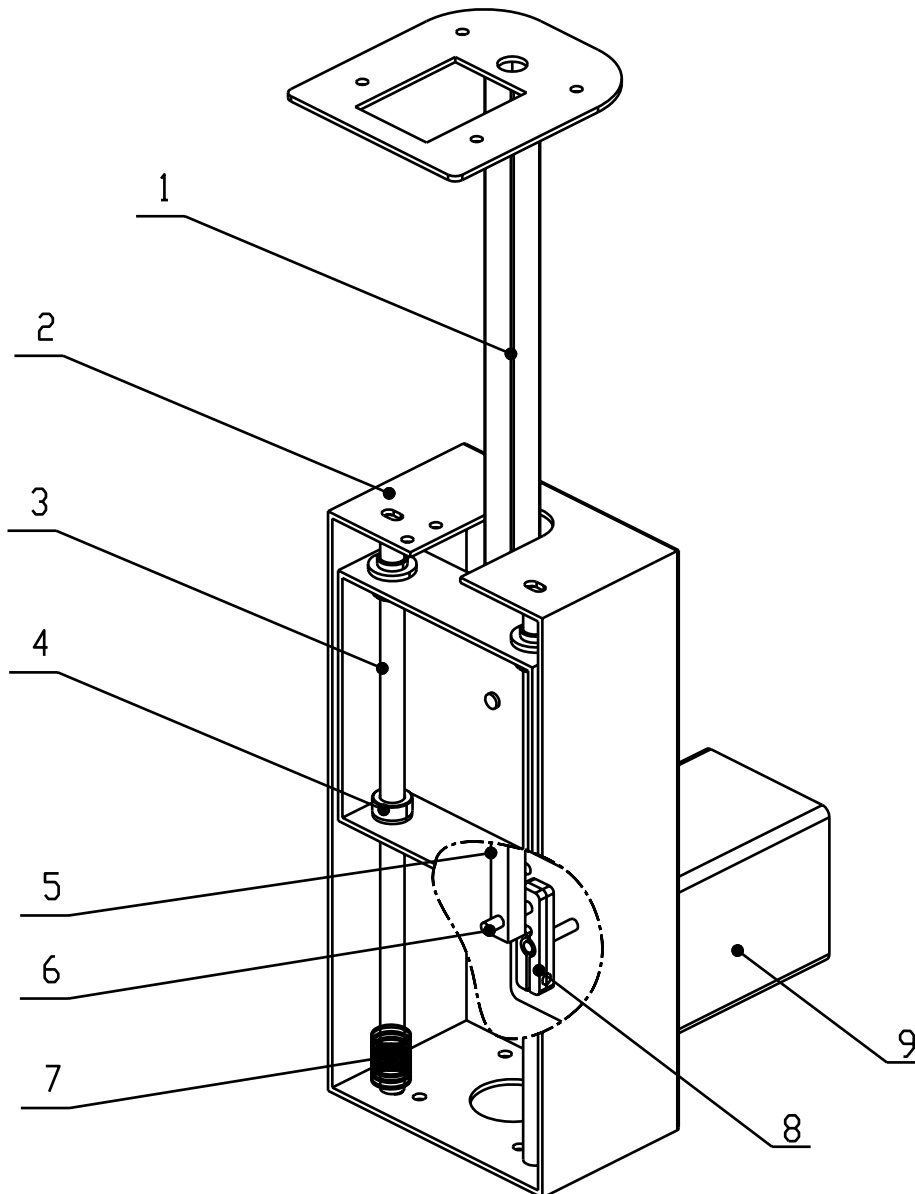
8.6 Up and Down Swing Assembly:

No.	Part No.	Name	Qty.
1	D109-134-000	Moving pole	1
2	D109-135-000	Underprop	1
3	D109-136-000	Guide track	2
4	D109-605-000	sleeve	4
5	D109-137-000	Connect pole B	1
6	D109-419-000	Bearing	2
7	D109-138-000	Spring	1
8	D109-139-000	Rocker_arm B	1
9	D109-420-000	Motor	1

8.7 Mouth Assembly:

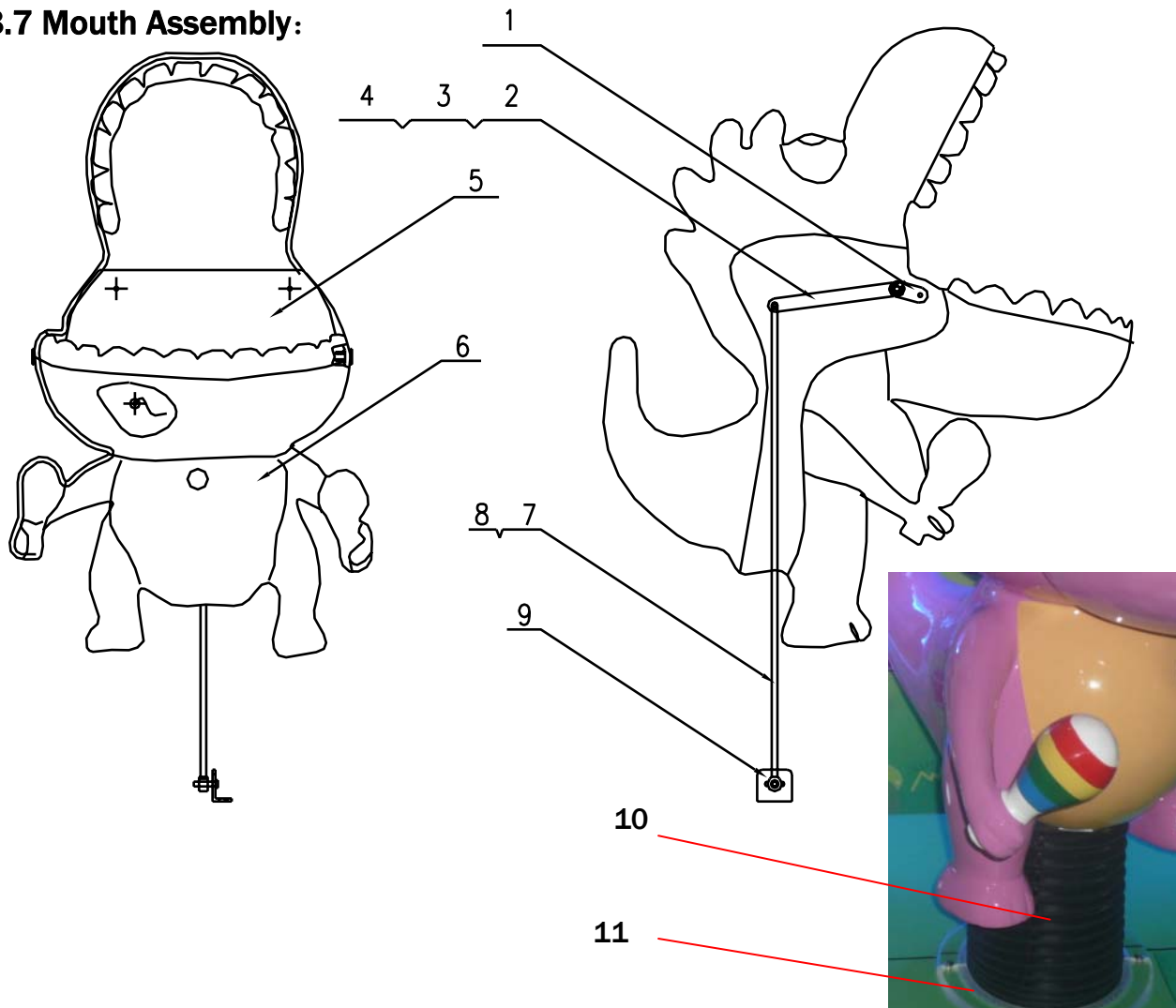

No.	Part No.	Name	Qty.
1	D109-140-000	Circumrotate arm	2
2	D109-141-000	Connect sleeve	1
3	D109-142-000	Ring	1
4	D109-143-000	R type pin	1
5	D109-606-000	Baffle	1
6	D109-607-000	Dino	1
7	D109-144-000	Connect pole	1
8	D109-421-000	Bearing	1
9	D109-145-000	Fixation board	1
10	D109-608-000	Rubber skirt	1
11	D109-609-000	Clear plastic	2

8.8 Counter & Wire box:

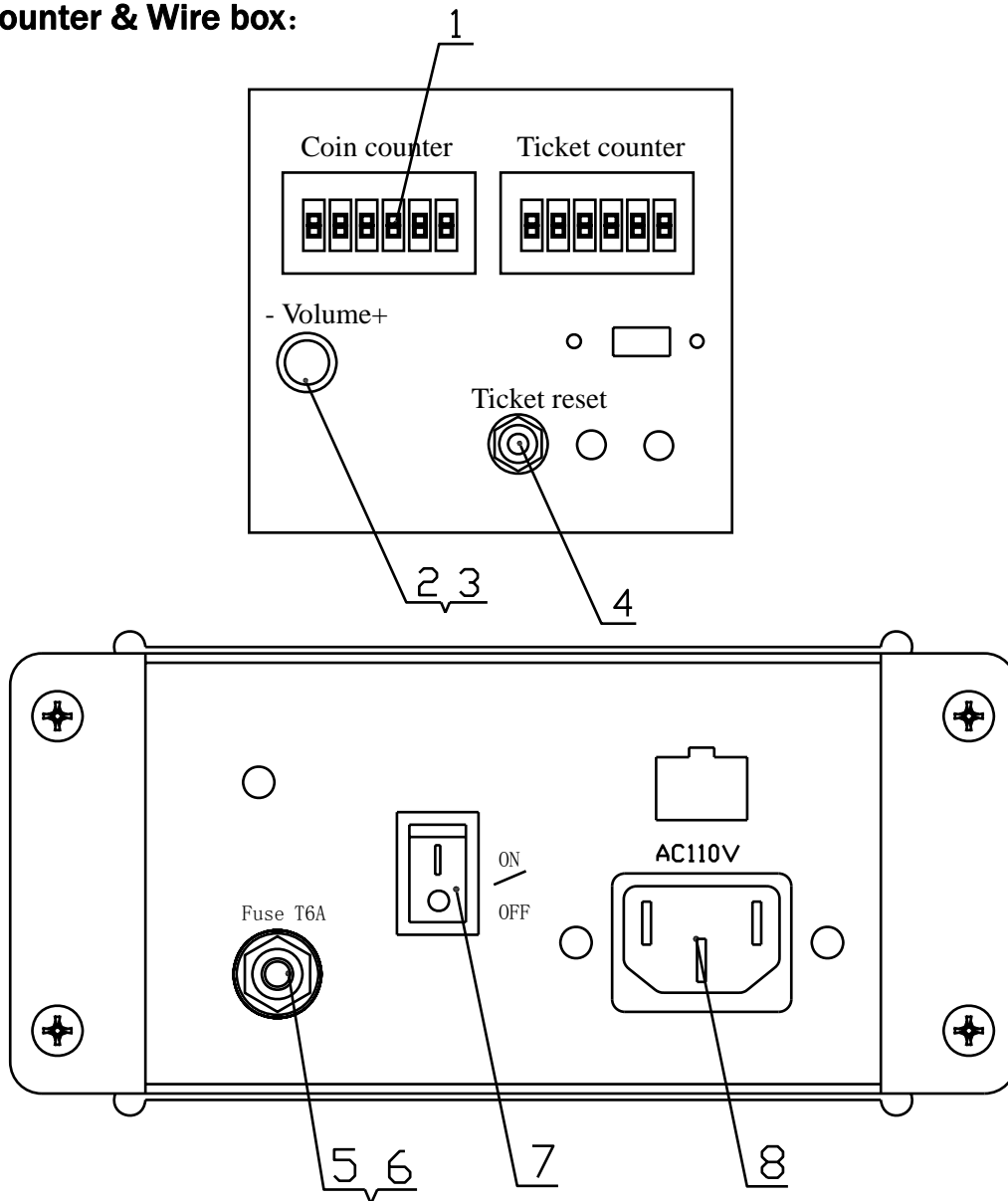

No.	Part No.	Name	Qty.
1	D109-422-000	Counter	1
2	D109-423-000	Pot. knob	1
3	D109-424-000	Pot. Connected board	1
4	D109-425-000	Button	1
5	D109-426-000	T6A 125VAC Fuse	1
6	D109-427-000	Fuse holder	1
7	D109-428-000	SW	1
8	D109-429-000	Noise filter	1

8.9 Electrical Parts:

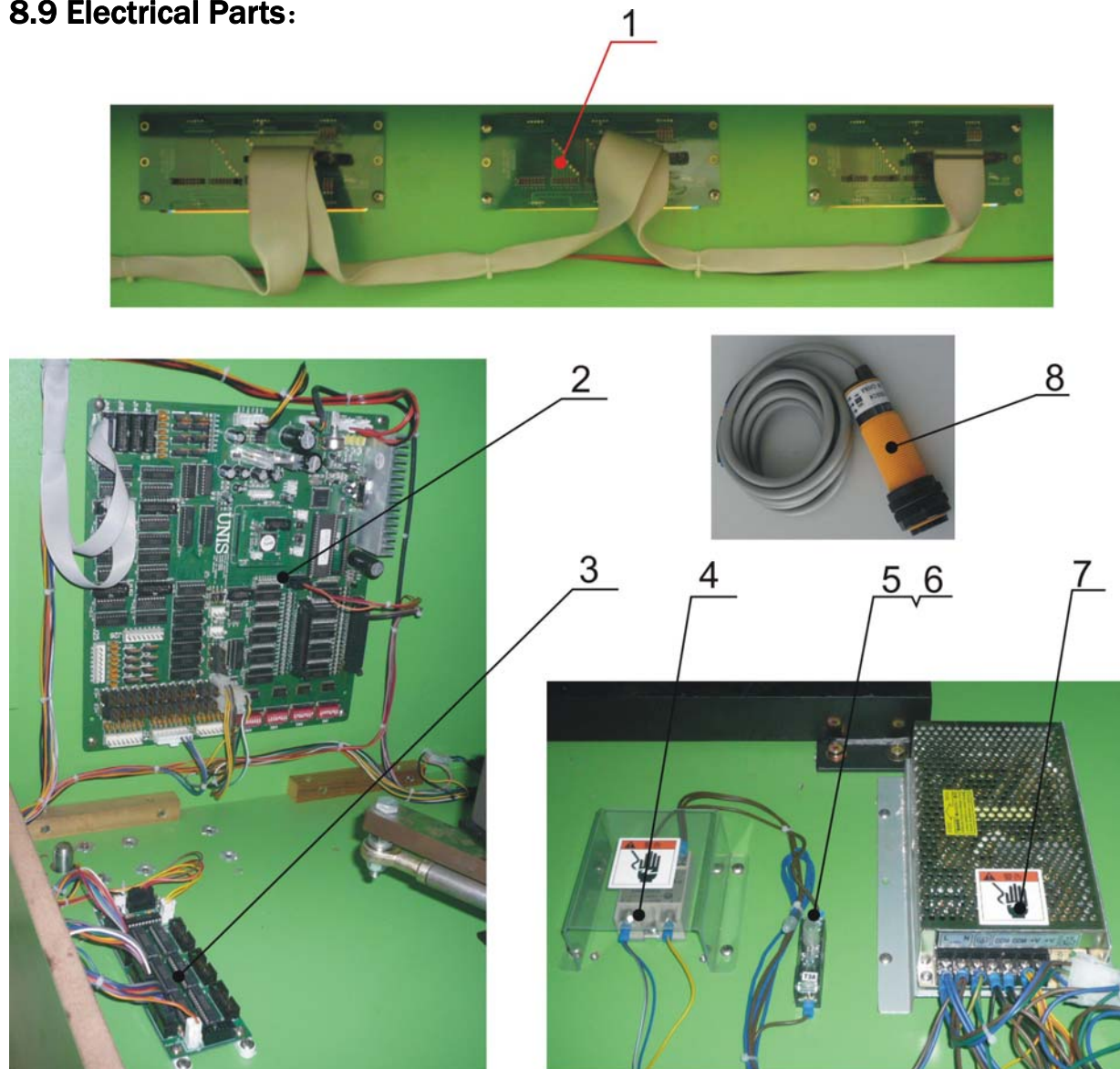

No.	Part No.	Name	Qty.
1	D109-801-000	2.3" LED	3
2	D109-802-000	Main board	1
3	D109-803-000	Lamp control board	1
4	D109-430-000	Relay	1
5	D109-431-000	Fuse	1
6	D109-432-000	Fuse holder	1
7	D109-433-000	Power supply	1
8	D109-434-000	Sensor	1

8.10 Game Decals:

Front :

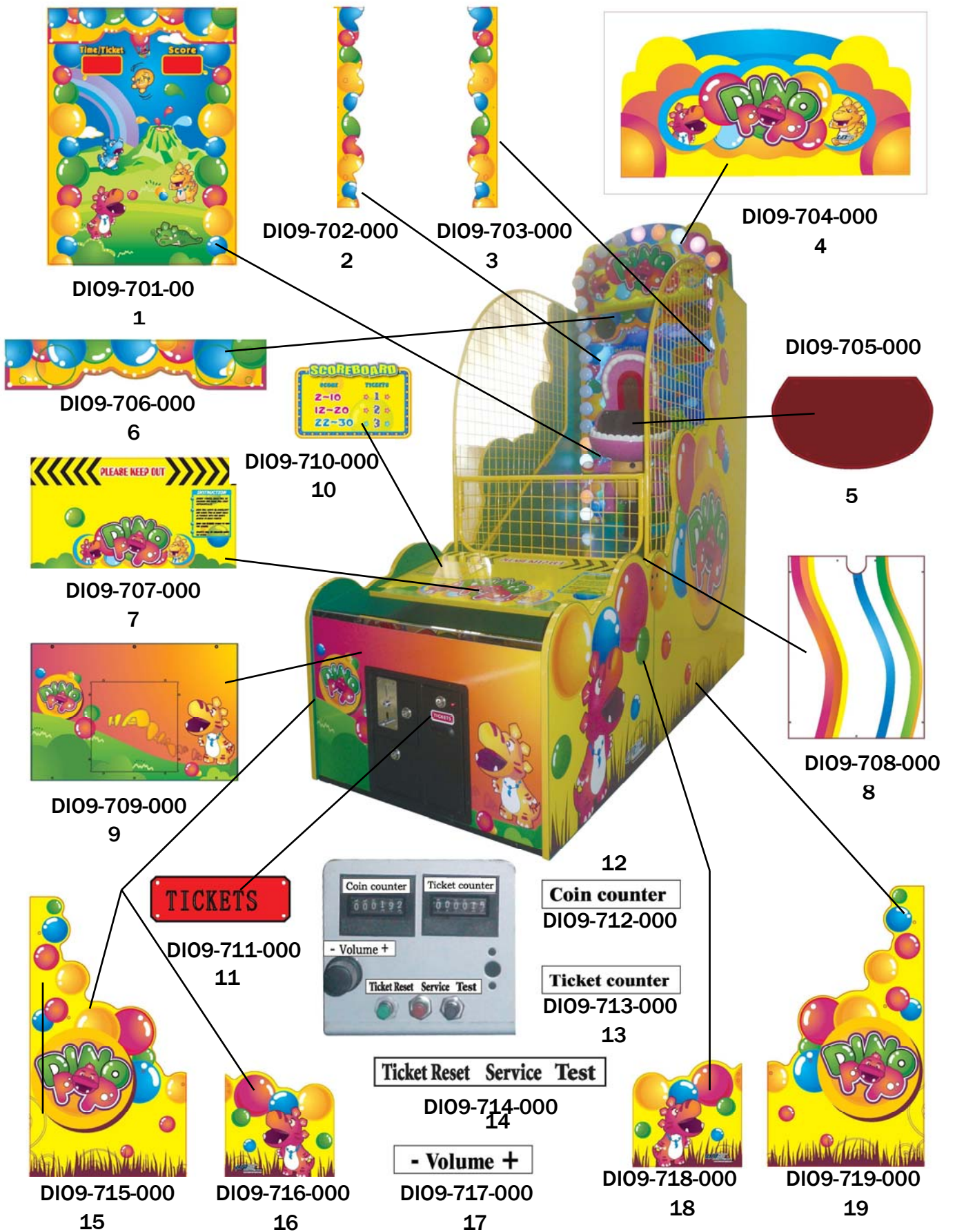

No.	Part No.	Name	Qty.
1	D109-701-000	Main decal	1
2	D109-702-000	Main decal - L	1
3	D109-703-000	Main decal - R	1
4	D109-704-000	Marquee	1
5	D109-705-000	Mouth decal	1
6	D109-706-000	Main decal - top	1
7	D109-707-000	Control panel decal	1
8	D109-708-000	Playfield decal	1
9	D109-709-000	Front door decal	1
10	D109-710-000	Score board decal	1
11	D109-711-000	Ticket payout decal	1
12	D109-712-000	Coin counter decal	1
13	D109-713-000	Ticket counter decal	1
14	D109-714-000	Ticket reset decal	1
15	D109-715-000	Side rear decal - L	1
16	D109-716-000	Side front decal - L	1
17	D109-717000	Volume decal	1
18	D109-718-000	Side front decal - R	1
19	D109-719-000	Side rear decal - R	1

Back :

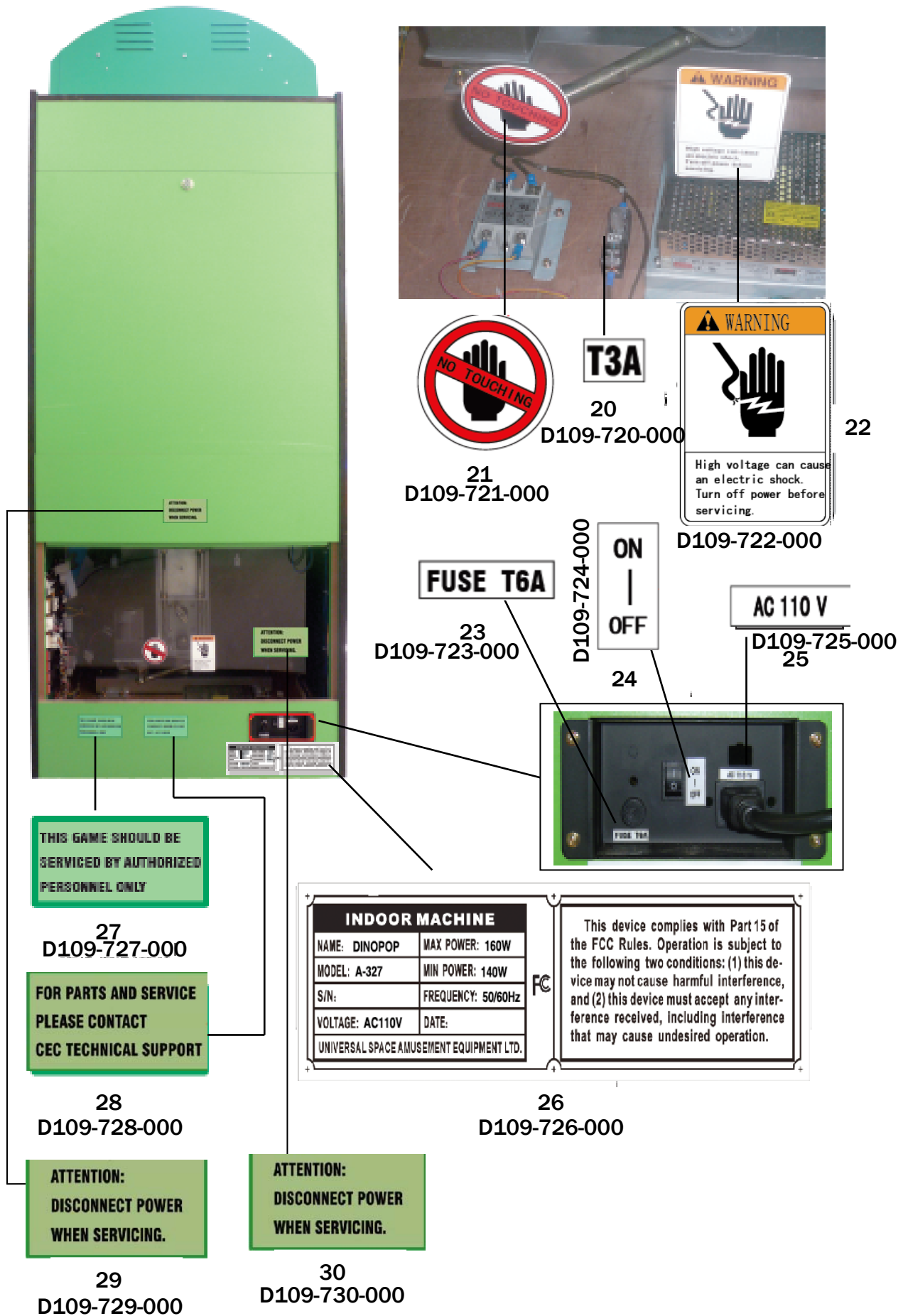

No.	Part No.	Name	Qty
20	D109-720-000	T3A decal	1
21	D109-721-000	No touching decal	1
22	D109-722-000	High voltage decal (small)	1
23	D109-723-000	Fuse T6A decal	1
24	D109-725-000	Power SW decal A	1
25	D109-726-000	Label 110V	1
26	D109-730-000	FCC certified nameplate	1
27	D109-731-000	CEC service label 1	1
28	D109-732-000	CEC service label 2	1
29	D109-734-000	Attention label	2
30	D109-735-000	Plastic shield label	1