

# ARKA



 **Be  
Sure to Read  
this Manual  
Before Use**

## Operation Manual

**SERIAL NUMBER**

**DATE OF INSTALLATION**

# CONTENT

Important Safety Instructions .....	2
1. SPECIFICATIONS .....	4
2. PACKAGE CONTENTS.....	5
3. PART NAMES .....	6
4. SET UP & INSTALLATION.....	7
5. HOW TO PLAY .....	10
6. GAME OPTION .....	10
7. MAINTENANCE, INSPECTION.....	11
8. OVERALL CONSTRUCTION .....	13



## WARNING

Non-technical personnel who do not have technical knowledge and Expertise should refrain from performing such work that this manual require or perform tasks which are not explained in this manual. Failing to comply can cause severe accidents such as electric shock or other serious injuries. All repairs must be performed to original manufacturer specifications.

**WARNING: To reduce the risk of fire, electric shock or personal injury, unplug or disconnect the machine from the power supply before servicing.**

Thank you for purchasing Arka. We hope you enjoy the product.

This manual contains valuable information about how to operate and maintain your game machine properly and safely. It is intended for the owner and/or personnel in charge of product operation. Carefully read and understand the instructions.

If you need any help during installation and setup please utilize this manual and troubleshooting guide. If the product fails to function properly, *non-technical personnel should under no circumstance attempt to service the machine*. Contact your distributor or manufacturer for help.

Before use, please read **IMPORTANT SAFETY INSTRUCTIONS**.

---

## IMPORTANT SAFETY INSTRUCTIONS

**To ensure the safe usage of this product, carefully read and understand these instructions before operating your game. Save these instructions for future reference.**

Use this product only as described in this manual. Other uses not recommended may cause fire, electric shock or personal injury. Unplug the game from the outlet when not in use, when moving from one location to another, and before cleaning/servicing.

Explanations which require special attention are indicated by signs of warning. Depending on the potential hazardous degree, the terms: **NOTE**, **NOTICE**, and **WARNING** are used.

**NOTE:** A NOTE indicates useful hints or information about product usage.

**NOTICE:** A NOTICE indicates potential damage to product and how to avoid the problem.

**WARNING:** A WARNING indicates a potential for product damage or serious personal injury.

It is important to understand the meaning of the following HAZARD SIGNS before continuing:

### High Voltage and Shock Hazard:

High voltage can cause electric shock.  
Turn off/unplug power before servicing.



### High Temperature Hazard:

This part may cause scalding.  
Do not touch. Surface may be hot.



**No Touching Hazard:**

This part may be hot or can cause electric shock.

Do not touch.



---

Use the following safety guidelines to help ensure your own personal safety and to help protect your equipment and surrounding environment from potential damage.

 **This product is an indoor game machine. Do not install outdoors.**

Avoid installing in the following places to prevent fire, electric shock, injury and/or machine malfunctioning:

- Places subject to rain/moisture, or places subject to high humidity.
- Places subject to direct sunlight, or places subject to extremely hot or cold temperatures to ensure that it is used within the specified operating range.
- Places where inflammable gas may be present or in the vicinity of highly inflammable/volatile chemicals or items that can easily catch fire
- On unstable or sloped surfaces. The machine may topple or cause unforeseen accidents.
- Vicinity of fire exits, fire extinguishers etc that may block/prevent safety measures

**Important Note**

**All repairs must be done to original manufacturer specifications. Failure to do so will void all warranties and operator assumes all risks.**

Note: The contents of this manual may be updated without notice.

# 1. SPECIFICATIONS

Rated power supply:	AC220-240V 50/60Hz
Power consumption:	Min power consumption : 25W Max power consumption : 400W
Dimensions:	W30.7×D70×H69.2 (inch)
Weight:	About 242.5 (lb)

 **NOTICE:** After turning off the game, please wait at least 1 minute before restarting again.

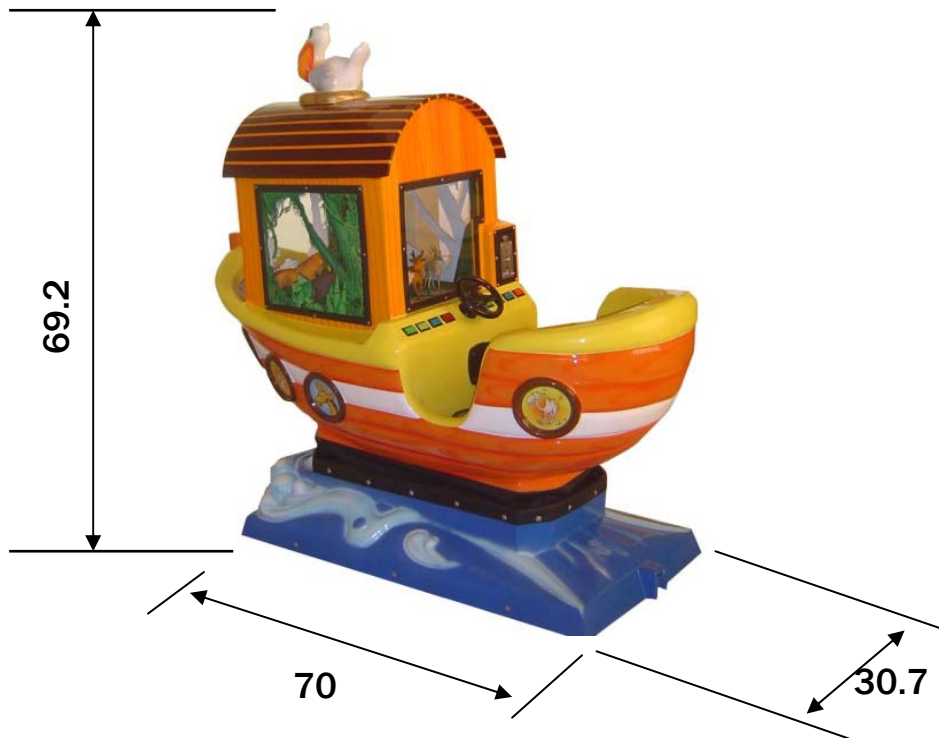



**Note:** Game parameters are subject to change without notice

## 2. PACKAGE CONTENTS

Open the package and make sure all the items are included:

- 1 x Body Assembly
- Following accessories

No.	Part Number	Component	Specification	Illustration	Qty.
1	A103-709-000	Operation Manual	ENGLISH		1
2	A103-426-000	Key	C582		1
3	A103-421-000	Relay	LIRRD-LLY2/DC12V		1
4	A103-427-000	Wrench			1

**If any items are found to be missing, please contact your sales representative for help immediately.**

**Warranty: Universal Space provides 90 days warranty for all electrical and mechanical components, when used under normal operating conditions. Any modification or abuse of these items immediately voids the warranty. Graphic and consumable items are exempt from any warranty.**

**NOTE:** Part models are subject to change without notice.



## 4. SET UP & INSTALLATION

 **This product is an indoor game machine. Do not install outdoors.**

- Refer to IMPORTANT SAFETY INSTRUCTIONS (Pg. 3) for places to avoid.
- Place the unit on a dry level surface.
- Ventilation openings in the back of the unit must not be obstructed by objects or by wall.

### 4.1 Play Zone

This machine requires space for playing and for maintenance as shown here.

Leave space around the game upon installation:

Service area: 19.7 inches

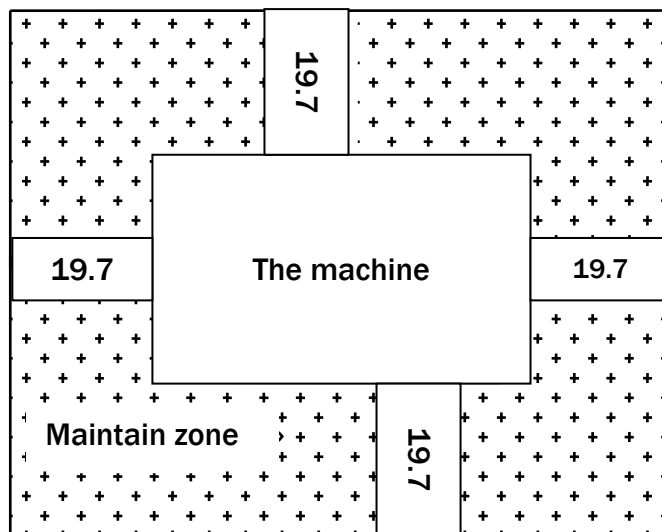



## 4.2 Level Adjustment

Install this machine on a flat surface. Adjust levers to lift casters off the ground to level the game. If the game is installed on an unsuitable floor, it could cause a malfunction.

To fix the game, adjust the Leveler down until it touches the floor, lifting the casters off the ground by 5mm. Repeat the same for all levelers.

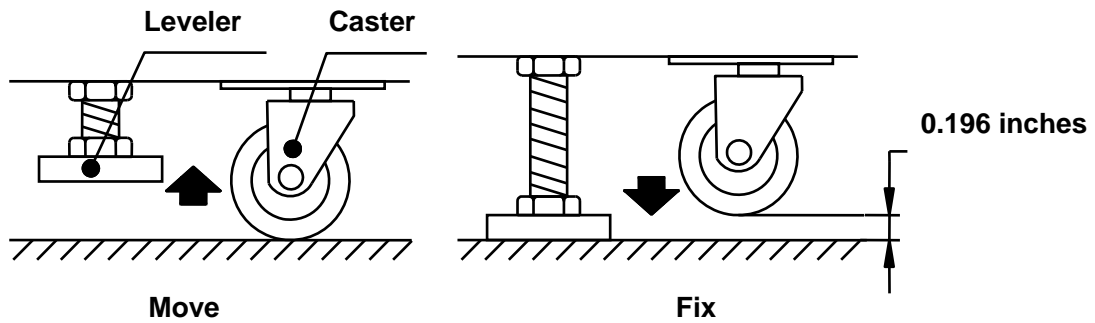

### NOTICE

Make sure the machine is level with the ground and all the adjustable legs should stick to the floor closely.

## 4.3 Transporting the Game

Use a trolley to move the game. Insert the hook end into the hole on the ride and push down to move it.

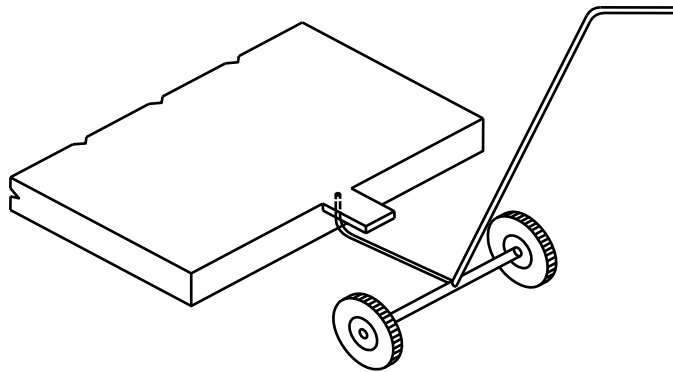

### NOTICE

- Be careful not to damage the machine during transport.
- The machine should be handled with care when bringing it down from a higher level.
- Always unplug the game before moving.
- Keep the machine in upright position during transport.
- For longer distance transport, package the game properly to prevent damages
- Do not lay game on side during transport.

## 4.4 Connecting Power

**⚠ WARNING:** Check the voltage rating before you connect the equipment to an electrical outlet to ensure that the required voltage and frequency match the available power source. Please refer to the label on the machine.

- Do not plug the equipment power cables into an electrical outlet if the power cable is damaged.
- Avoid putting many loads on one electrical outlet as it could generate heat and fire resulting from overload.
- Connect the grounding conductor to the earth terminal (GND):

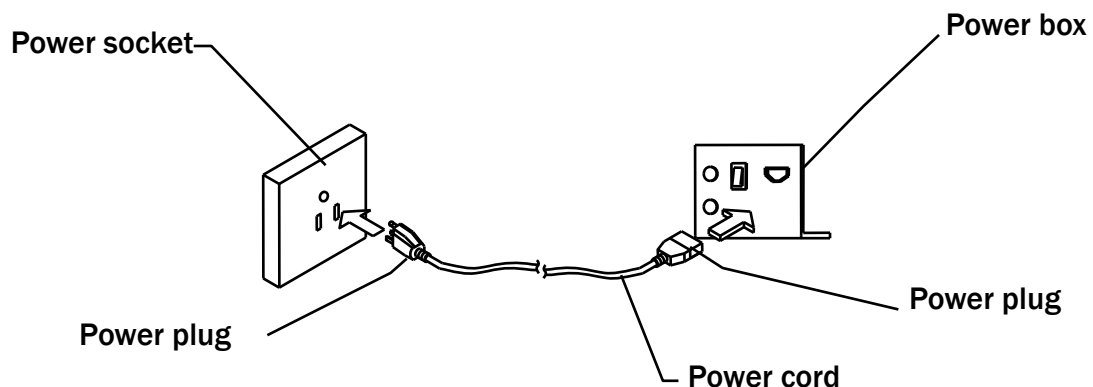

### WARNING

Ensure no heavy objects rest on the power cord. Check to make sure the game cabinet does not sit on the power cord as this could damage the cord and become hazardous.

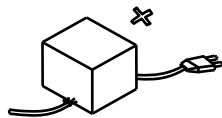

To disconnect the game, grip the plug and pull it from the wall outlet. Never pull by the cord.

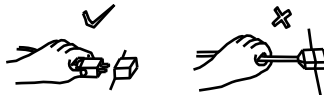

To prevent electric shock, do not touch the power plug when hand is wet.



Ensure that nothing rests on the power cord and that it is not located where it can be stepped on or tripped over.



## 5. HOW TO PLAY

- Fasten the seat belt. Insert coin(s), and game will START Automatically.
- The boat will move while playing.
- There are 8 buttons on the control panel. Press one of them and the corresponding animals will lift up and make a sound.
- Enjoy the ride and have fun.

## 6. GAME OPTION

### 6.1 Dip Switches Settings

Default settings are in capital letters.

DIP Adjust 1 (SW1)

(1) Coin(s) per game

Item	Content	DIP Adjust (SW1)		Note
		1	2	
Coin	1	ON	ON	
	2	off	Off	
	3	on	Off	
	4	off	off	

(2) Game play time(s)

Item	Content	DIP Adjust (SW1)			Note
		3	4	5	
Game play time(s)	45	ON	ON	ON	
	6	off	on	on	
	75	on	off	on	
	90	off	off	on	
	120	on	on	off	
	150	off	on	off	
	180	on	off	off	
	240	off	off	off	

**Note: Game parameters are subject change without notice**

## 6.2 Input and Output Settings

INPUT	Content	INPUT	Content
IN4-2	Button1#	IN5-2	Button8#
IN4-3	Button2#	IN5-3	SW
IN4-4	Button3#	IN5-4	Inset coin
IN4-5	Button4#	IN5-5	Service
IN4-6	Button5#	IN5-6	Test
IN4-7	Button6#	IN5-7	
IN4-8	Button7#	IN5-8	

OUTPUT	Content	OUTPUT	Content	OUTPUT	Content
LED1-1	Lamp(button1)	LED2-9	Embed lamp2(left)	SOL1	1#Motor
LED1-2	Lamp(button2)	LED2-10	Embed lamp2(right)	MT2	2#Motor
LED1-3	Lamp(button3)	LED3-9	Embed lamp3(left)	SOL2	3#Motor
LED1-4	Lamp(button4)	LED3-10	Embed lamp3(right)	MT4	4#Motor
LED1-5	Lamp(button5)	LED4-9	Embed lamp4(left)	SOL3	5#Motor
LED1-6	Lamp(button6)	LED4-10	Embed lamp4(right)	MT6	6#Motor
LED1-7	Lamp(button7)			SOL4	7#Motor
LED1-8	Lamp(button8)			MT8	8#Motor
LED1-9	Embed lamp1(left)			MT7	Main Motor
LED1-10	Embed lamp1(right)				

## 7. MAINTENANCE, INSPECTION

### 7.1 Safety Check

Check the points listed before operating the machine. These checks are necessary for safe machine operation:

1. Try to run the game before operation each day.
2. Conduct monthly routine checks of game components ensure good working condition
3. Check the machine regularly for dust and clean when necessary.

**Note:** Parts and components require preventative maintenance to be kept running smoothly

### 7.2 Handling Precautions

When installing or inspecting the machine, be very careful of the following points and pay attention to ensure that the player can enjoy the game safely.

Non-compliance with the following points or inappropriate handling running counter to the cautionary matters herein stated can cause personal injury or damage to the machine.



## WARNING

- Before servicing the machine, be sure to turn power off. Servicing without turning the power off can cause electric shock or short circuit.
- To avoid electric shock or short circuit, do not plug then unplug the power quickly
- Do not expose power cords and earth wires, these are susceptible to damage.
- Damaged cords and wires can cause electric shock or short circuit and should be replaced immediately.
- When or after installing the product, avoid pulling the power cord to prevent unnecessary wear and tear. Use the power button to disconnect power.
- In case the power cord is damaged, ask for replacement through where the product was purchased from or replace locally. Continued usage of damaged cord can cause fire, electric shock or leakage.
- Perform grounding appropriately. Inappropriate grounding can cause electric shock. Use fuses that meet specified rating. Fuses exceeding can cause an electric shock.
- Should a problem occur, turn off the power immediately and stop operating the machine. Unplug the power cord of the service outlet. Operating the machine without correcting the problem may cause a fire or injuries.
- Insert the power plug securely into the outlet. Poor contact may cause overheating, resulting in fire or burns.
- To ensure the warning labels attached on the machine are visible and legible, install the machine in a well-lit location, and keep the labels clean at all times. Make sure the labels are not hidden behind other game machines.

## 8. OVERALL CONSTRUCTION

### 8.1 Main Assembly 1

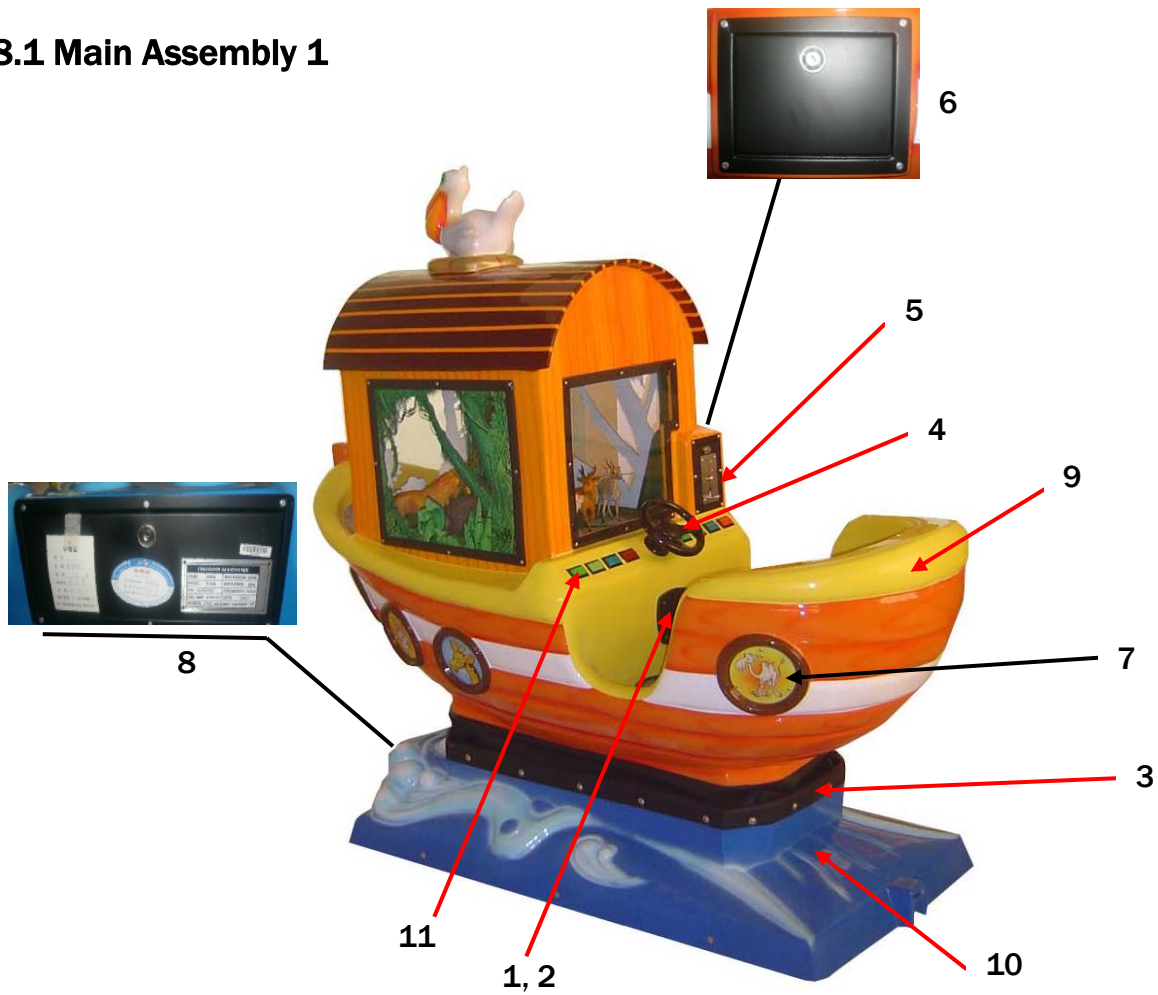

NO.	Part no.	Name	Qty
1	A103-101-000	Speaker grill	1
2	A103-401-000	Speaker	1
3	A103-601-000	Skirt	1
4	A103-102-000	Steering wheel	1
5	A103-103-000	CEC Coin mech.	1
6	A103-104-000	Coin box	1
7	A103-402-000	PCB light	8
8	A103-105-000	Electric box	1
9	A103-106-000	Fiberglass ship	1
10	A103-403-000	Fiberglass base	1
11	A103-426-000	Button	8

## 8.2 Main Assembly 2

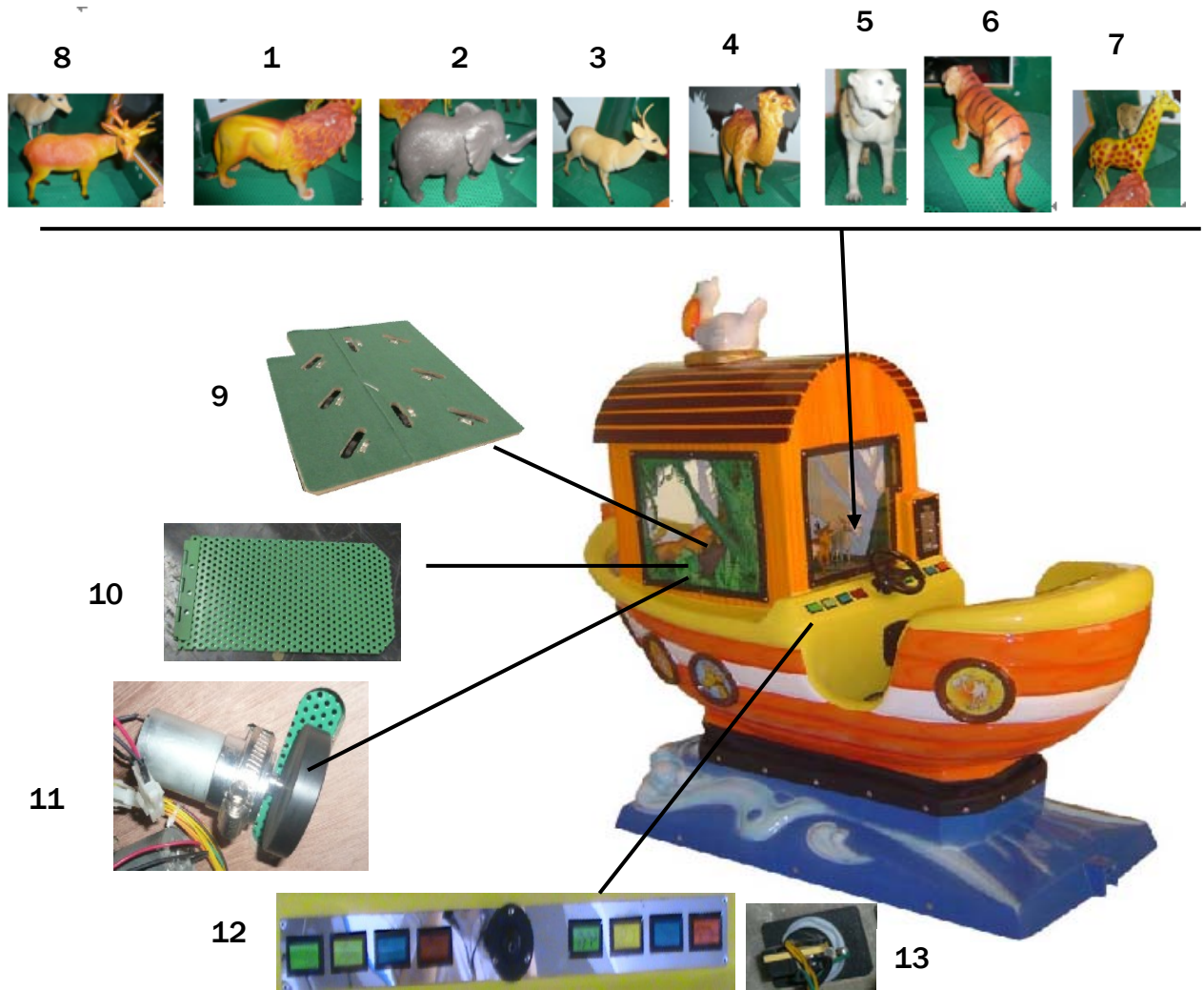

NO.	Part No.	Name	Qty
1	A103-404-000	Lion figure	1
2	A103-405-000	Elephant figure	1
3	A103-406-000	Antelope figure	1
4	A103-407-000	Camel figure	1
5	A103-408-000	Leopard figure	1
6	A103-409-000	Tiger figure	1
7	A103-410-000	Giraffe figure	1
8	A103-411-000	Dear figure	1
9	A103-501-000	Carpet plate	1
10	A103-107-000	Animal base	8
11	A103-412-000	Lift up motor	8
12	A103-120-000	Control panel plate	1
13	A103-422-000	Button sensor	8

### 8.3 Base Assembly

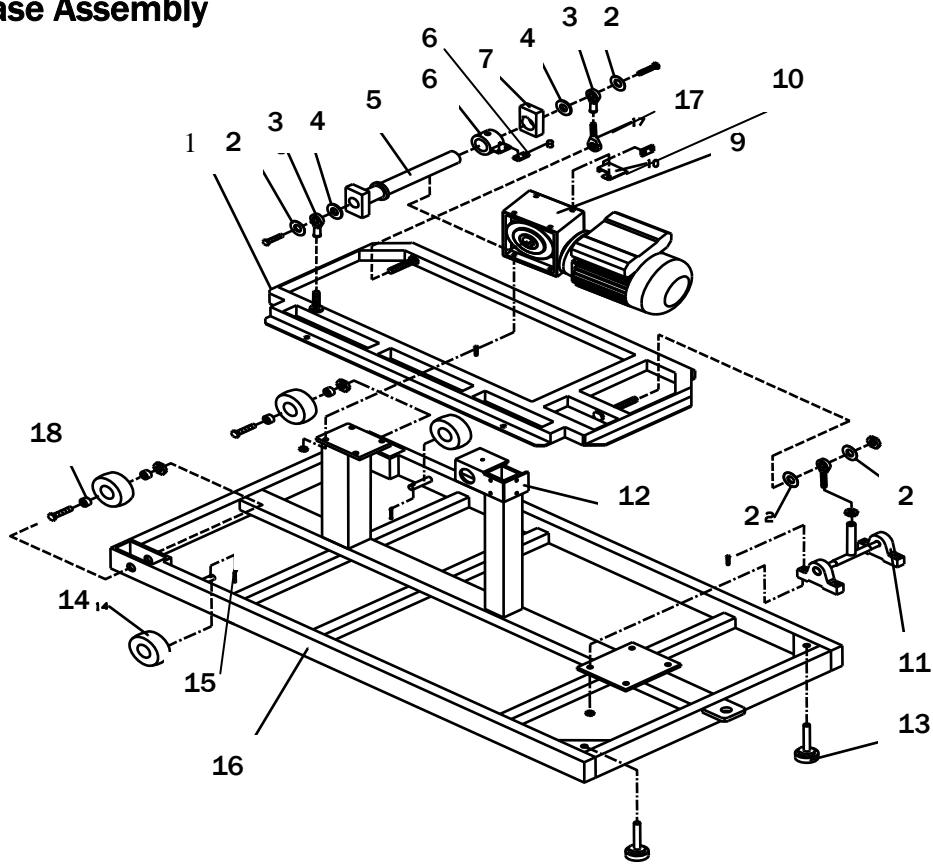

NO.	Part No.	Name	Qty
1	A103-108-000	Rocking Bracket	1
2	A103-109-000	Limit Block1	4
3	A103-413-000	Oscillating Bearing	2
4	A103-110-000	Limit Block2	2
5	A103-111-000	Excursion axis	1
6	A103-112-000	Reset Block1	1
7	A103-113-000	Excursion Block	1
8	A103-414-000	Magnetism SW	2
9	A103-415-000	Motor	1
10	A103-114-000	Reset Block2	1
11	A103-115-000	Bearing Base	2
12	A103-116-000	Connect Bracket	1
13	A103-416-000	Adjuster	2
14	A103-417-000	Castor	4
15	A103-117-000	Pin	2
16	A103-118-000	Base Board	1
17	A103-418-000	Oscillating Bearing	1
18	A103-119-000	Block	4



## 8.4 Electric Box Assembly

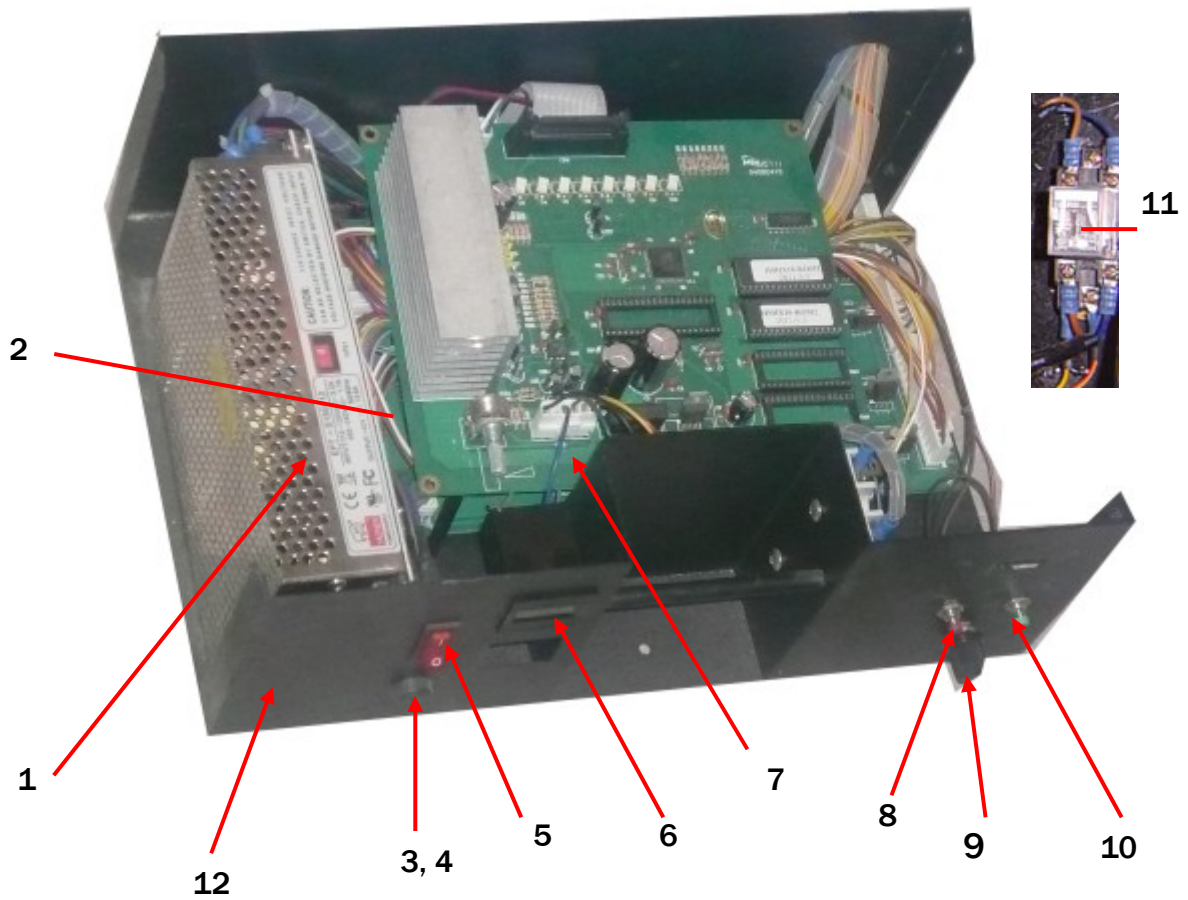

NO.	Part No.	Name	Qty
1	A103-419-000	Power supply	1
2	A103-801-000	Main board	1
3	A103-420-000	Fuse	1
4	A103-423-000	Fuse socket	1
5	A103-424-000	Power SW	1
6	A103-425-000	Coin Counter	1
7	A103-802-000	Music main board	1
8	A103-406-000	Service button (red)	1
9	A103-407-000	Volume knob	1
10	A103-408-000	Test button (green)	1
11	A103-421-000	Control relay(For main motor)	1
12	A103-121-000	Electric box	

### 8.5 Decals

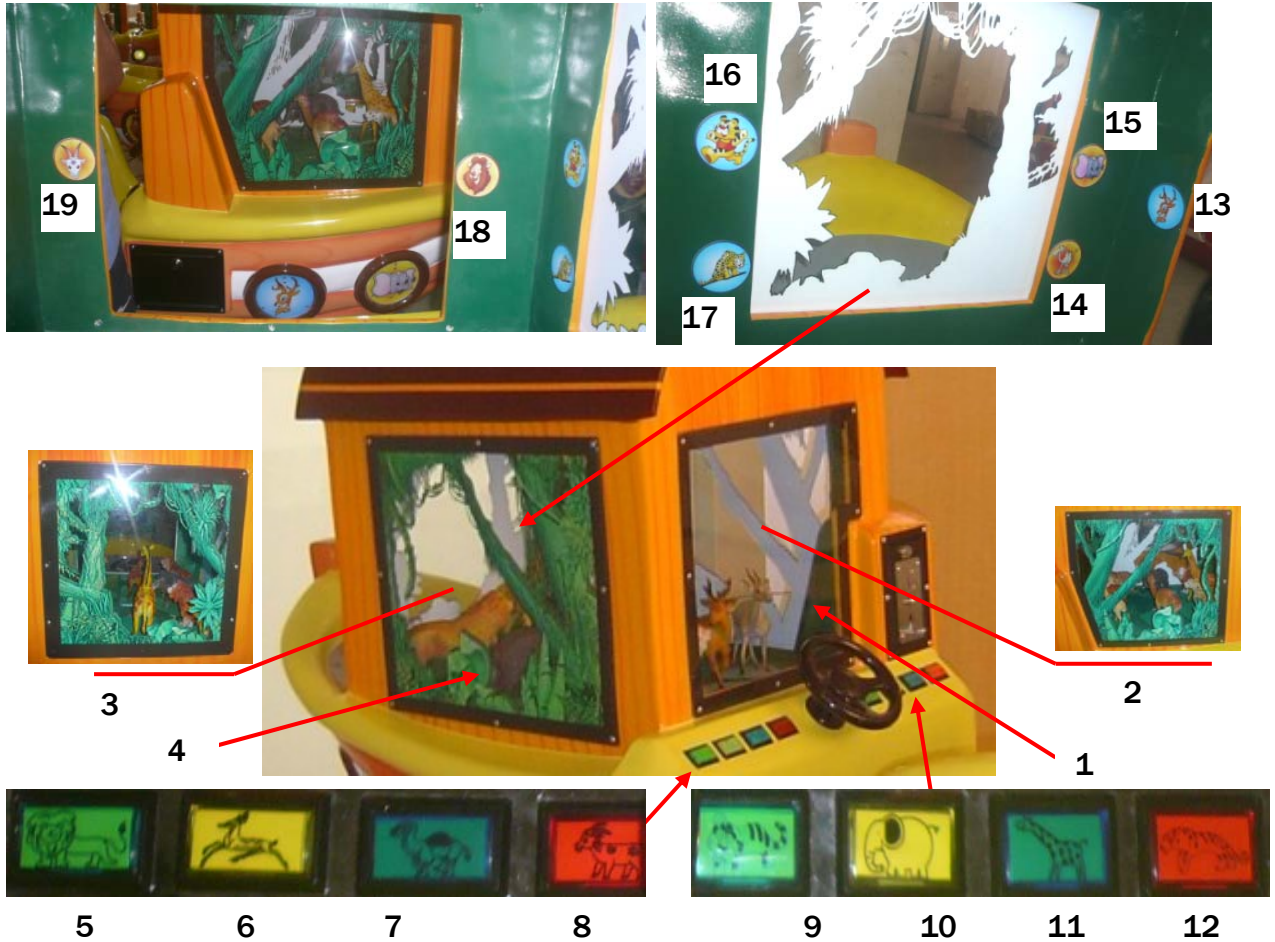

NO.	Part NO.	Name	Qty
1	A103-602-000	Front window decal	1
2	A103-603-000	Left window decal	1
3	A103-604-000	Back window decal	1
4	A103-605-000	Right window decal	1
5	A103-606-000	Lion button decal	1
6	A103-607-000	Dear button decal	1
7	A103-608-000	Camel button decal	1
8	A103-609-000	Antelope button decal	1
9	A103-610-000	Tiger button decal	1
10	A103-611-000	Elephant button decal	1
11	A103-612-000	Giraffe button decal	1
12	A103-613-000	Leopard button decal	1
13	A103-614-000	Dear window decal	1
14	A103-615-000	Camel window decal	1
15	A103-616-000	Elephant window decal	1
16	A103-617-000	Tiger window decal	1
17	A103-618-000	Leopard window decal	1
18	A103-619-000	Lion window decal	1
19	A103-620-000	Antelope window decal	1

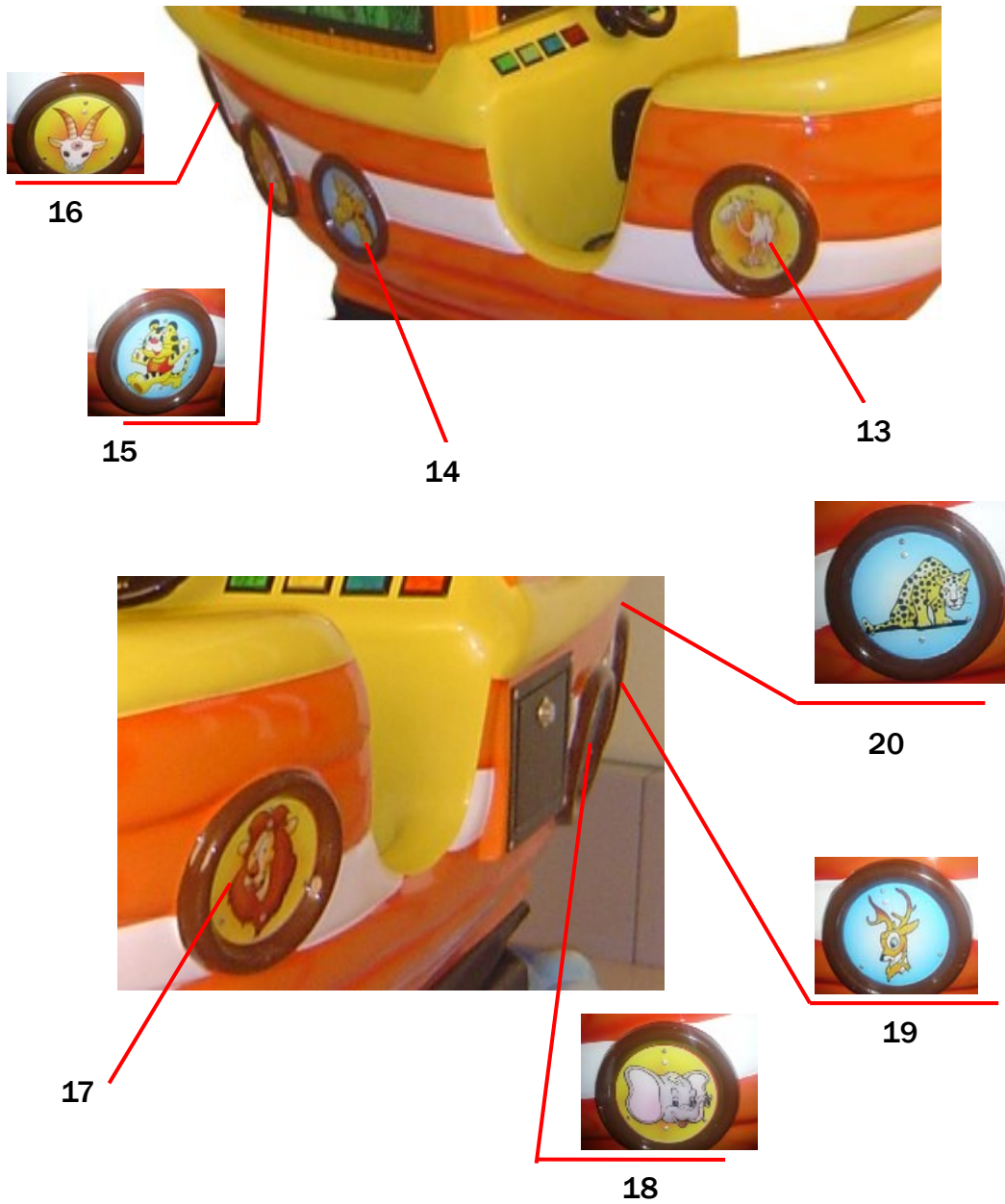

NO	Part No.	Name	Qty
13	A103-701-000	Camel side decal	1
14	A103-702-000	Giraffe side decal	1
15	A103-703-000	Tiger side decal	1
16	A103-704-000	Antelope side decal	1
17	A103-705-000	Lion side decal	1
18	A103-706-000	Elephant side decal	1
19	A103-707-000	Deer side decal	1
20	A103-708-000	Leopard side decal	1